

Vi1408VPD

8-Ch Powered VPD Combiner

Features

- Supports up to 8 cameras by providing Video, class II Power, and Data on a single Cat-5 cable per camera
- 8 isolated camera power individually selectable 24 or 28 VAC at 1 A max per channel, 6 A aggregated
- A glass fuse per channel, accesable from front panel
- Used with the Vi1053VPD transceiver at the camera
- Power present and fault indicator LEDs for each camera
- 19", low profile 1U wall or rack-mountable
- Designed for structured wiring applications
- Limited Lifetime warranty



Applications

- Security and Surveillance
- Department Store Security
- Casino Security
- Hospitals and Airports
- Structured Wiring Applications

Power Distance Chart

Power Supply Voltage		12 VDC	24 VAC	28 VAC
Voltage at the camera		11.5 VDC	21 VAC	21 VAC
100 mA Camera	Dual 24 AWG	175 ft	1,000 ft	2,500 ft
	Dual 22 AWG	300 ft	1,500 ft	4,000 ft
300 mA Camera	Dual 24 AWG	50 ft	350 ft	850 ft
	Dual 22 AWG	100 ft	600 ft	1,400 ft
1 Amp Camera	Dual 24 AWG	15 ft	100 ft	250 ft
	Dual 22 AWG	30 ft	150 ft	400 ft

The Vi1408VPD is an advanced device that combines video, PTZ data, and camera power over a single 4-pair UTP cable to simplify CCTV installations in a structured wiring environment. It supports up to 8 cameras and is designed to be placed at a location between the cameras and control room to extend the video up to 3,000 feet. The Vi1408VPD has 8-ch fully isolated class II built-in 28/24 VAC power supply. Each camera power output is equipped with a glass fuse for extra protection. All fuses are easily accessible from front.

At the camera end the Vi1053VPD video balun/combiner provides Video, power and data on separate outputs. The Vi1408VPD can be installed at the "Head End" or "mid-span". The video connections are through four RJ45 and Cat-5 cables passive or active UTP receiver. The data connections to the DVR are through 4-pair RJ-45 cables. There is a separate data connection for each camera. All equipment follow industry-standard EIA/TIA 568B pinouts. The Vi1408VPD is an ideal CCTV component for structured cabling environment.

Application Diagram

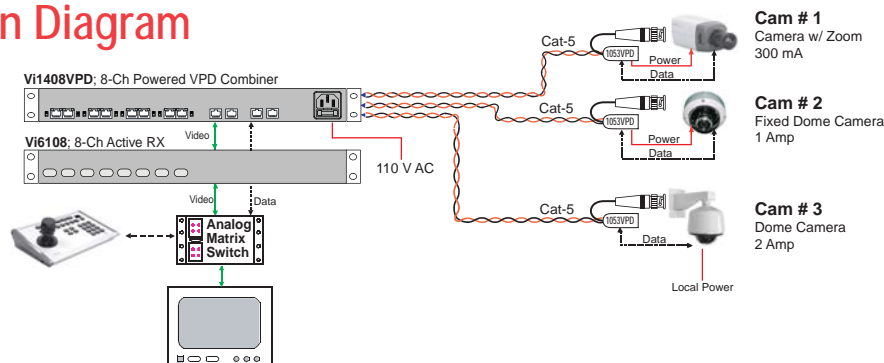

The smart choice for quality video

www.vigitron.com

DSVi1408VPD_0707



Technical Specification*

Electrical

Input Voltage	110 VAC or 220 VAC, internally switch selectable
Input Current	2.4 Amps (110 VAC) / 1.2 Amps (220 VAC)
Camera Power	Voltage: Isolated Class II, switch selectable 24 V AC, off, or 28V AC Current: 1 A Max per camera, 6 A Max aggregated
Fault Protection	2 A glass fuse (front access) per camera
Twisted Pair (UTP)	100 Ohms +/- 20%, 24 AWG min, Category 2-7
Diagnostics LEDs	No Load or Shut down: 8 Red LEDs, one per channel Power Present: 8 Green LEDs, one per channel
Connectors	Camera Connection: RJ-45 Connector Data: RJ-45 Connector Control Room Video: RJ-45 Connector
Transient Immunity	per ANSI 587 C62.41

Environmental

Humidity	0 to 95%, non-condensing
Temperature	Operating: -20C to +50C Storage: -30C to +70C
Minimum Airflow	3 ft /min
Heat	700 BTU/hour

Mechanical

Dimensions	1.75x17x12 Inches, 4.3x43x30.5 cm (HxWxL)
Weight	12 Lb, 5.5 Kg
Material	Steel Sheet Metal

*Specifications subject to change without notice.

Ordering Information

PART No.	Description
Vi1408VPD	8-Ch Powered VPD Combiner
Vi1416VPD	16-Ch Powered VPD Combiner

System Configuration

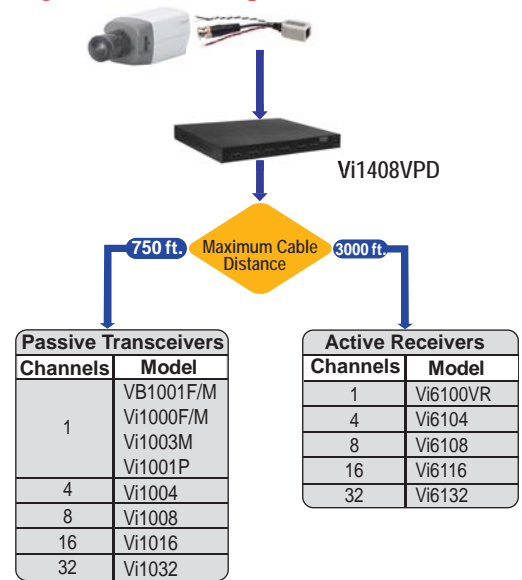

Camera Connections:

Pin#	VPD
1	Video +
2	Video -
3	Data +
4	Power-
5	Power+
6	Data -
7	Power+
8	Power-

Control Room Video Connections:

Pin#	Video Group	Related Cameras
1	Video-A+	Camera 1,2,3,4
2	Video-A-	Camera 1,2,3,4
3	Video-B+	Camera 5,6,7,8
4	Video-C-	Camera 5,6,7,8
5	Video-C+	Camera 9,10,11,12
6	Video-B-	Camera 9,10,11,12
7	Video-D+	Camera 13,14,15,16
8	Video-D-	Camera 13,14,15,16

Control Room Data Connections:

Pin#	Data Group	Related Cameras
1	Data-A+	Camera 1,2,3,4
2	Data-A-	Camera 1,2,3,4
3	Data-B+	Camera 5,6,7,8
4	Data-C-	Camera 5,6,7,8
5	Data-C+	Camera 9,10,11,12
6	Data-B-	Camera 9,10,11,12
7	Data-D+	Camera 13,14,15,16
8	Data-D-	Camera 13,14,15,16

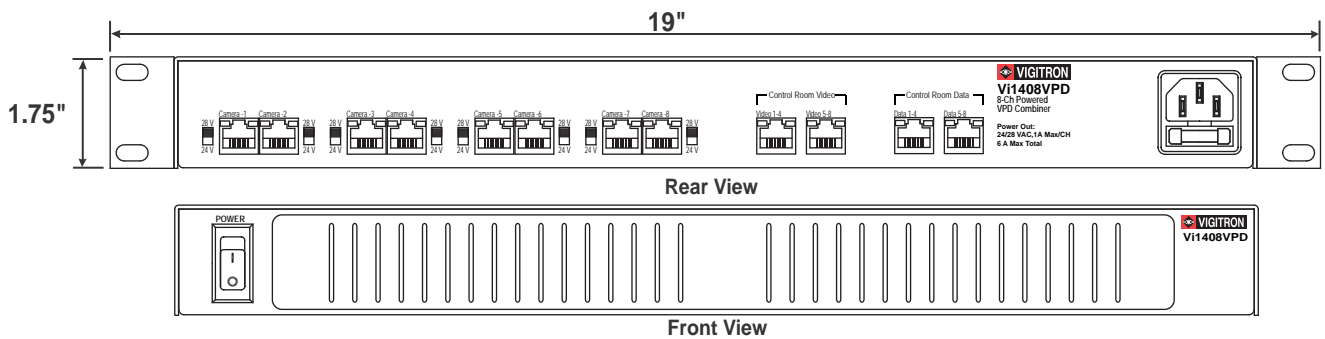

Wire and Cable Recommendations

The Vigitron products are designed to be used with unshielded twisted pair (UTP) wiring. The UTP wire must be 24AWG - 12AWG or Category 2 - 7 cable. Multi-pair cable with an overall shield is acceptable, however individually shielded pairs should be avoided, Multiple UTP Video feeds can be operated in the same communication cable along with telephone, computer, control signals and low power voltages. While UTP video may be routed through punch-down block terminals, any resistive, capacitive or inductive devices (such as T-taps or MOV's) must not be used, . For more specific information regarding wire types and proper installation techniques, please contact Vigitron for technical assistance.



TEL (+1) 858-484-5209 • FAX (+1) 858-484-1205
13906 Sparren Ave. San Diego, CA 92129, USA • info@vigitron.com • www.vigitron.com