

WAS-WASPT

WASHER PUMP AND 5 OR 23 LITRE TANK



IP66



WASHERS AND TANKS

The Videotec WAS-WASPT is a wash kit consisting of a water tank with an integrated pump for PTZ cameras and camera housings equipped with wiper.

This wide range of washers and tanks is available with capacities of 5 or 23 litres and delivery heads up to 30 metres.

With the WASPT series it is possible to remotely control via RS-485 the wiper and the washer pump by using the DTWRX optional board.

In the 11m (36ft) and 30m (98ft) delivery versions the lack of liquid in the tank is signalled following the automatic stop of the pump (except for 11m (36ft) version of WAS series).

Pumps with 30m (98ft) delivery are available only in 230Vac or 120Vac.

With the use of the antifreeze liquid the minimum operating temperature goes down to -25°C (-13°F).

Products with 5m (16ft) or 11m (36ft) delivery heads have an IP66 level of protection.

The WASPT0V23L11M00 washer pump with tank of 23l (6gal) and delivery head 11m (36ft) is certified "Lloyd's Register Marine Type Approval", also in conjunction with the DTWRX card.

CERTIFICATIONS



only valid for the pump with a 23l (6gal) tank and 11m (36ft) delivery head in the WASPT series

MAIN FEATURES

Polyethylene tank with stainless steel cage

Delivery head: 5m (16ft), 11m (36ft), 30m (98ft)

Versions with alarm for the lack of liquid in the tank

Also for third-party products

Operating temperature: from -10°C (14°F) up to +60°C (140°F)

Available voltages: 230Vac, 120Vac, 24Vac

IP protection degree (EN60529): IP66 (only products with 5m (16ft) or 11m (36ft) delivery head)

The WASPT0V23L11M00 washer pump with tank of 23l (6gal) and delivery head 11m (36ft) is certified "Lloyd's Register Marine Type Approval"

Washer pump, tank of 5l (1.3gal), 5m (16ft) delivery

Polyethylene tank, stainless steel cage

Dimensions (WxHxL): 217x280x257mm (8.5x11x10.1in)

Cable glands: 1xM20 + 3xM16

Unit weight: 3.5kg (7.7lb) (WAS), 3.8kg (8.4lb) (WASPT)

Water tank capacity: 5l (1.3gal)

Delivery head: 5m (16ft) max

Tube length: 5m (16ft)

Supply voltage/Current consumption:

- 230Vac, 0.3A, 50/60Hz
- 120Vac, 0.6A, 50/60Hz
- 24Vac, 1.8A, 50/60Hz

Operating temperature

- Maximum temperature: 60°C (140°F)
- Minimum temperature with antifreeze liquid in solution: -10°C (14°F)
- Minimum temperature with antifreeze liquid in solution (reduced performance and delivery height): -25°C (-13°F)

Electrical safety (CE): EN60950-1, EN62368-1

Electromagnetic compatibility (CE): EN50130-4, EN61000-6-3, EN55032 (Class B), FCC Part 15 (Class B)

Outdoor installation (CE): EN60950-22

IP protection degree (EN60529):

- IP66

EAC certification

Washer pump, tank of 23l (6gal), 5m (16ft) delivery

Polyethylene tank, stainless steel cage

Dimensions (WxHxL): 301x430x348mm (11.8x16.9x13.7in)

Cable glands: 1xM20 + 3xM16

Unit weight: 5.4kg (11.9lb) (WAS), 5.5kg (12.1lb) (WASPT)

Water tank capacity: 23l (6gal)

Delivery head: 5m (16ft) max

Tube length: 5m (16ft)

Supply voltage/Current consumption:

- 230Vac, 0.3A, 50/60Hz
- 120Vac, 0.6A, 50/60Hz
- 24Vac, 1.8A, 50/60Hz

Operating temperature

- Maximum temperature: 60°C (140°F)
- Minimum temperature with antifreeze liquid in solution: -10°C (14°F)
- Minimum temperature with antifreeze liquid in solution (reduced performance and delivery height): -25°C (-13°F)

Electrical safety (CE): EN60950-1, EN62368-1

Electromagnetic compatibility (CE): EN50130-4, EN61000-6-3, EN55032 (Class B), FCC Part 15 (Class B)

Outdoor installation (CE): EN60950-22

IP protection degree (EN60529):

- IP66

EAC certification

Washer pump, tank of 23l (6gal), 11m (36ft) delivery

Polyethylene tank, stainless steel cage

Dimensions (WxHxL): 301x430x348mm (11.8x16.9x13.7in)

Cable glands: 1xM20 + 3xM16

Unit weight: 5.9kg (13lb) (WAS), 6.7kg (14.8lb) (WASPT)

Float level switch (except for 11m (36ft) version of WAS series)

Water tank capacity: 23l (6gal)

Delivery head: 11m (36ft) max

Tube length: 11m (36ft)

Supply voltage/Current consumption:

- 230Vac, 0.5A, 50/60Hz
- 120Vac, 1A, 50/60Hz
- 24Vac, 3.8A, 50/60Hz

Alarm outputs:

- Auto-powered: 1
- Dry contact: 1

Operating temperature

- Maximum temperature: 60°C (140°F)
- Minimum temperature with antifreeze liquid in solution: -10°C (14°F)
- Minimum temperature with antifreeze liquid in solution (reduced performance and delivery height): -25°C (-13°F)

Electrical safety (CE): EN60950-1, EN62368-1

Electromagnetic compatibility (CE): EN50130-4, EN61000-6-3, EN55032, (Class B), FCC Part 15 (Class B)

Outdoor installation (CE): EN60950-22

IP protection degree (EN60529):

- IP66

EAC certification

Marine Certification: Lloyd's Register Marine Type Approval (only for the 11m (36ft) version in the WASPT series)

Washer pump, tank of 23l (6gal), 30m (98ft) delivery

Polyethylene tank, stainless steel cage

Dimensions (WxHxL): 301x640x269mm (11.9x25.2x10.6in) (WAS), 301x640x348mm (11.9x25.2x13.7in) (WASPT)

Cable glands: 1xM20 + 3xM16

Unit weight: 13.9kg (30.6lb) (WAS), 16.7kg (36.8lb) (WASPT)

Water tank capacity: 23l (6gal)

Delivery head: 30m (98ft) max

Tube length: 30m (98ft)

Float level switch

Supply voltage/Current consumption:

- 230Vac, 2A, 50/60Hz
- 120Vac, 4.5A, 60Hz

Alarm outputs:

- Auto-powered: 1
- Dry contact: 1

Operating temperature

- Maximum temperature: 60°C (140°F)
- Minimum temperature with antifreeze liquid in solution: -10°C (14°F)

Electrical safety (CE): EN60950-1, EN62368-1

Electromagnetic compatibility (CE): EN50130-4, EN61000-6-3, EN55032, (Class B), FCC Part 15 (Class B)

Outdoor installation (CE): EN60950-22

IP protection degree (EN60529):

- IPX4

EAC certification

PART NUMBER	
WASOV5L5M00	Water tank 5l (1.3gal), pump with delivery up to 5m (16ft), IN 230Vac-24Vac-120Vac
WASOV23L5M00	Water tank 23l (6gal), pump with delivery up to 5m (16ft), IN 230Vac-24Vac-120Vac
WASOV23L11M00	Water tank 23l (6gal), pump with delivery up to 11m (36ft), IN 230Vac-24Vac-120Vac
WAS1V23L30M00	Water tank 23l (6gal), pump with delivery up to 30m (98ft) with water floating, IN 230Vac
WAS3V23L30M00	Water tank 23l (6gal), pump with delivery up to 30m (98ft) with water floating, IN 120Vac
WASPTOV5L5M00	Water tank 5l (1.3gal), pump with delivery up to 5m (16ft), IN 230Vac-24Vac-120Vac
WASPTOV23L5M00	Water tank 23l (6gal), pump with delivery up to 5m (16ft), IN 230Vac-24Vac-120Vac
WASPTOV23L11M00	Water tank 23l (6gal), pump with delivery up to 11m (36ft) with water floating, IN 230Vac-24Vac-120Vac
WASPT1V23L30M00	Water tank 23l (6gal), pump with delivery up to 30m (98ft) with water floating, IN 230Vac
WASPT3V23L30M00	Water tank 23l (6gal), pump with delivery up to 30m (98ft) with water floating, IN 120Vac

ACCESSORIES	
COMB100A	Communication box in polycarbonate, IN from 220Vac up to 230Vac, OUT 24Vac
COMB200A	Communication box in polycarbonate, IN 24Vac, OUT 24Vac
COMB300A	Communication box in polycarbonate, IN from 120Vac up to 127Vac, OUT 24Vac
DTWRX	Data receiver for remote control of the wiper and WASPT range pumps in stand-alone housings
WASCAB	Cabinet for WAS/WASPT (only for versions with 5m and 11m head pump)

PACKAGE			
Model Number	Weight	Dimensions (WxHxL)	Master carton
WASOV5L5M00	4kg (8.8lb)	31x31x22cm (12.2x12.2x8.6in)	4
WASOV23L5M00	6.2kg (13.7lb)	32x37.5x51cm (12.5x14.7x20in)	-
WASOV23L11M00	5.9kg (13lb)	32x37.5x51cm (12.5x14.7x20in)	-
WAS1V23L30M00	13.1kg (28.9lb)	38x32x79cm (15x12.6x31.1in)	-
WASPTOV5L5M00	4.3kg (9.5lb)	31x31x22cm (12.2x12.2x8.6in)	-
WASPTOV23L5M00	6.4kg (14lb)	32x37.5x51cm (12.5x14.7x20in)	-
WASPTOV23L11M00	7.5kg (16.5lb)	32x37.5x51cm (12.5x14.7x20in)	-
WASPT1V23L30M00	17.1kg (37.7lb)	38x32x79cm (15x12.6x31.1in)	-
DTWRX	-	8.5x5.5x11.5cm (3.4x2.2x4.5in)	-

WAS - CONFIGURATION OPTIONS (NOT ALL COMBINATIONS ARE POSSIBLE)				
	Voltage	Water tank capacity	Delivery head	
WAS	0V 230Vac - 24Vac - 120Vac	5L 5l (1.3gal)	5M 5m (16ft)	00
	1V 230Vac	23L 23l (6gal)	11M 11m (36ft)	
	3V 120Vac		30M 30m (98ft)	

WASPT - CONFIGURATION OPTIONS (NOT ALL COMBINATIONS ARE POSSIBLE)				
	Voltage	Water tank capacity	Delivery head	
WASPT	0V 230Vac/ 24Vac/ 120Vac	5L 5l (1.3gal)	5M 5m (16ft)	00
	1V 230Vac	23L 23l (6gal)	11M 11m (36ft)	
	3V 120Vac		30M 30m (98ft)	

TECHNICAL DRAWINGS

The indicated measurements are expressed in millimetres.

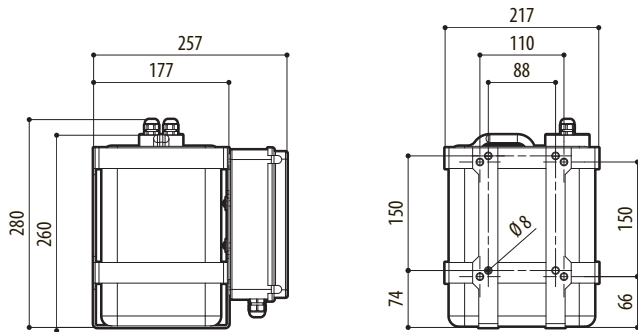

WATER TANK 5L (1.3GAL), 5M (16FT) DELIVERY (WAS-WASPT)

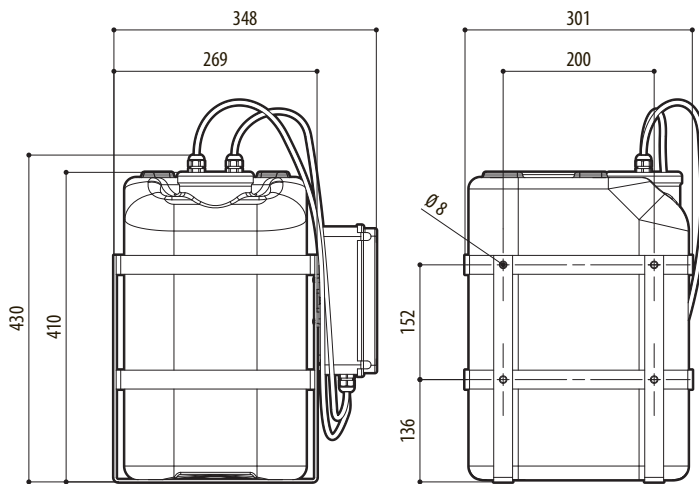

WATER TANK 23L (6GAL), 5M (16FT) DELIVERY (WAS-WASPT) Ø 11M (36FT) (WAS)

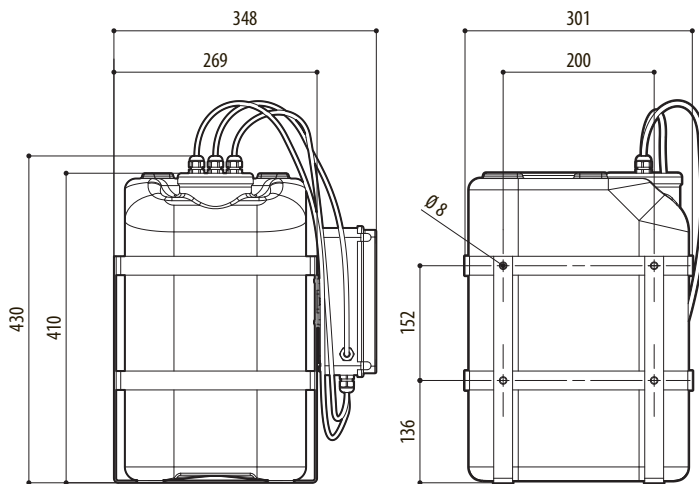

WATER TANK 23L (6GAL), 11M (36FT) DELIVERY (WASPT)

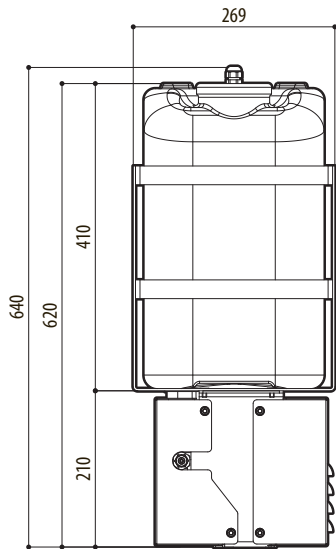

WATER TANK 23L (6GAL), 30M (98FT) DELIVERY (WAS)

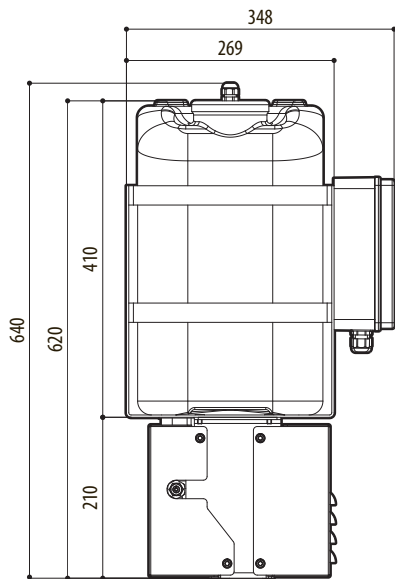
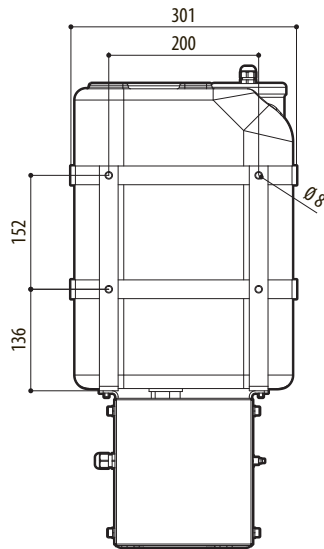

WATER TANK 23L (6GAL), 30M (98FT) DELIVERY (WASPT)

