

NXL

LARGE HOUSING FOR AGGRESSIVE ENVIRONMENTS

MAIN FEATURES

Made of AISI 316L electropolished stainless steel

IP66/IP67

Cylindrical body enclosed by two circular flanges, 12mm (0.47in) thick the front flange and 9mm (0.35in) thick the back flange

4 PG13,5 cable glands nickel-plated brass for external connections

Available accessories: heater, camera power supply, wiper, washer pump

DESCRIPTION

The NXL housing, entirely constructed from AISI 316L electropolished stainless steel, has been designed to accommodate large cameras and zoom lenses. The housing is conceived to operate in special environments such as salt water applications like marine or coast patrol, industrial or chemical applications, and where external agents are highly corrosive.

The housing offers the possibility to remove either the front or the back cover for adjusting the lens and various connections.

A wide range of accessories is available: heater, camera power supply, NXWBL stainless steel wall bracket, and the VIPNXL wiper.

The NXL housing can be installed on NXPTH Pan & Tilt head, to obtain a complete positioning system.



NXL



NXL + VIPNXL



NXL + NXWBL



NXL + VIPNXL + NXPTH + NXFWBT + NXWBPTH

AVAILABLE MODELS				
Model Number	Sunshield	Heater 120/230Vac	Heater 12Vdc/24Vac	Max consumption
NXL1K1000	✓	✓	–	40W
NXL2K1000	✓	–	✓	20W

TECHNICAL DATA

GENERAL

Constructed from electropolished stainless steel (austenitic alloy stainless steel, corrosion and heat resistant according to the following standards):

AISI 316L

UNI 6900-71: X 2 Cr Ni Mo 17 12 2

DIN 17006: X 2 Cr Ni Mo 17 13 2

N° werkstoff 1.4404

AFNOR: Z2 CND 17-12

BSI: 316S11

The screws utilised are in austenitic alloy stainless steel, corrosion and heat resistant according to the following standards:

- UNI 6900: X 5 Cr Ni Mo 1712
- AISI: 316
- ISO quality: A4
- Resistance class ISO: 80

UNI: Ente Nazionale Italiano di Unificazione, AISI: American Iron and Standard Institute, DIN: Deutsche Industrie Normen, AFNOR: Association Française de Normalisation, BSI: British Standard Institution, ISO: International Organization for Standardization.

MECHANICAL

Cable glands: 4xPG13.5 (nickel-plated brass for external connections)

12mm (0.5in) thick front and 9mm (0.35in) thick back flange

External body polishing

Gaskets: High sealing O-ring

Tempered window glass: Thick: 4mm (0.2in), Ø interno 150mm (5.9in), Ø esterno 168mm (6.6in)

External dimensions: Ø 200mm (7.9in), length 583mm (23in)

Internal usable area (WxH): 112x112mm (4.4x4.4in)

Internal usable length: 562mm (22.1in)

Internal usable length (with heater): 477mm (18.7in)

Internal usable length (with power supply and connection board): 465mm (18.3in)

Unit weight: 13kg / 28.7lb

ELECTRICAL

Heating (Ton 15°C±3°C (59°F ±5°F), Toff 22°C±3°C (77°F±5°F))

- Power supply/Consumption: IN 12Vdc/24Vac, 20W max
- Power supply/Consumption: IN 120/230Vac, 40W max

Camera power supply

- IN 100-240Vac - OUT 12Vdc, 50/60Hz, 1A
- IN 230Vac - OUT 24Vac, 50/60Hz, 400mA

ENVIRONMENT

Indoor/Outdoor

Operating temperature with heating: -20°C / +60°C (-4°F / +140°F)

CERTIFICATIONS

CE EN61000-6-3, EN60065, EN50130-4

IP66/IP67 EN60529 with cable glands

ACCESSORIES

ONXLH1	Heater 120/230Vac
ONXLH2	Heater 12Vdc/24Vac
ONXPS1B	Wide range power supply for camera IN 100-240Vac - OUT 12Vdc, 1A
ONXPS2B	Camera power supply IN 230Vac - OUT 24Vac, 400mA
VIPNXL1C	230Vac stainless steel wiper for NXL housing
VIPNXL2C	24Vac stainless steel wiper for NXL housing
WASOV5L5M00	Water tank 5l, pump with delivery up to 5m (16ft), IN 230Vac-24Vac-120Vac
WASOV23L5M00	Water tank 23l, pump with delivery up to 5m (16ft), IN 230Vac-24Vac-120Vac
WASOV23L11M00	Water tank 23l, pump with delivery up to 11m (36ft), IN 230Vac-24Vac-120Vac
WAS1V23L30M00	Water tank 23l, pump with delivery up to 30m (98ft) with water floating, IN 230Vac
WAS3V23L30M00	Water tank 23l, pump with delivery up to 30m (98ft) with water floating, IN 120Vac
WASPTOV5L5M00	Water tank 5l, pump with delivery up to 5m (16ft), IN 230Vac-24Vac-120Vac
WASPTOV23L5M00	Water tank 23l, pump with delivery up to 5m (16ft), IN 230Vac-24Vac-120Vac
WASPTOV23L11M00	Water tank 23l, pump with delivery up to 11m (36ft), IN 230Vac-24Vac-120Vac
WASPT1V23L30M00	Water tank 23l, pump with delivery up to 30m (98ft) with water floating, IN 230Vac
WASPT3V23L30M00	Water tank 23l, pump with delivery up to 30m (98ft) with water floating, IN 120Vac
DTWRX	Data receiver for remote control of the wiper and WASPT range pumps

RELATED PRODUCTS

NXPHT	Stainless steel Pan & Tilt
-------	----------------------------

BRACKETS AND ADAPTORS

NXWBL	Stainless steel wall bracket with joint
-------	---

PACKAGE

Model Number	Weight	Dimensions (WxHxL)	Master carton
NXL1K1000	15kg / 33.5lb	29.5x35x75cm (11.6x13.8x29.5in)	-

TECHNICAL DRAWINGS

Sizes in millimeters.

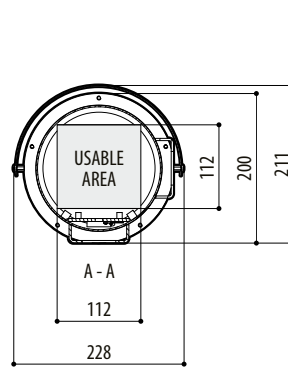
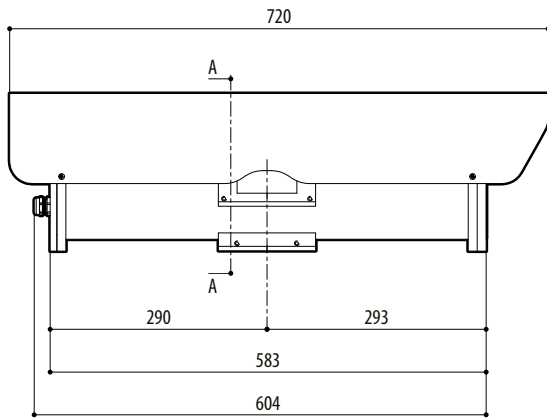

FRONT FLANGE

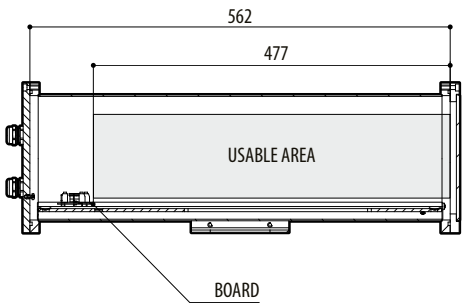
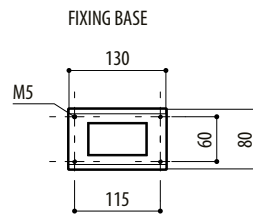
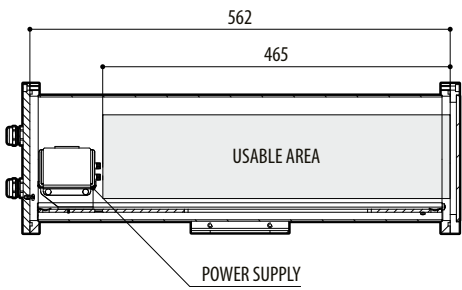
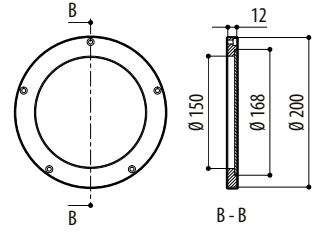

NXL

