

MAXIMUS MVX with SONY FCB-EV7520 camera



EXPLOSION-PROOF FULL HD CAMERA, FOR DAY/NIGHT VIEWING WITH EXCEPTIONAL NIGHT BRIGHTNESS

IP66/IP67
IP68/IP69

TYPE 4X
TYPE 6P



- Certifications for use in Zones 1 and 2, IIC T5 and T6 Group (Gas) and in Zones 21 and 22, IIIC T100°C and T85°C Group (Dust)
- Exceptional corrosion resistance
- Video recordings with incredibly bright day and night colours
- 4m (13ft) / 10m (32.8ft) preinstalled armoured multipolar cable with cable gland or, alternatively, with 4m (13ft) / 10m (32.8ft) cable tail

ONVIF® | QST

SONY®



MAXIMUM RESISTANCE IN THE MOST CRITICAL ENVIRONMENTS

The Full HD explosion-protected MAXIMUS MVX is perfect for effective video surveillance and process control in harsh settings where the presence of gases or flammable dust can create a potentially explosive environment, a reality often found in the oil and gas industries or marine and industrial sectors.

The housing is compact yet functional and is made entirely out of AISI 316L stainless steel. Its resistance to corrosion is not only guaranteed, but is also enhanced by way of polishing processes.

Another important feature of the camera is the extended certification temperature range of -60°C to 65°C, along with a sophisticated cold start system, which allows it to operate in harsh environments as standard.

An equally noteworthy point is that the IP66/IP67/IP68 ratings guarantee the complete protection against harsh weather and submersion in up to 5 metres of water for 2 hours. Moreover, the IP69 rating allows the device to be cleaned with high pressure water jets.

One striking advantage offered by these cameras is their extremely easy and secure “plug and play” installation, with multipolar wiring. These cameras arrive ready to use, avoiding the complex electrical connections that are typical of this type of device.

The MAXIMUS MVX series products are Lloyd's Register Type Approval System Test Specification Number 1 certified and therefore can be used in Marine and Offshore applications for environmental categories ENV1, ENV2, ENV3 and ENV5 (eg. passenger ships, open-air decks, closed spaces and technical areas that may be subject to heat generated by other equipment, potentially explosive areas, docking procedures).

SONY FCB-EV7520 CAMERA

MAXIMUS MVX with the SONY FCB-EV7520 camera has a 30x optical zoom and a 1/2.8” Exmor R™ CMOS sensor with Full HD 1080/60p resolution that produces the highest image quality, even when surveilling moving objects or in poor lighting conditions. The advanced SONY technology brings Wide Dynamic Range and a configurable High Light Compensation that allows optimal management of contrasting light and dark conditions. The camera's high sensitivity means you get colour video with a minimum illumination of just 0.0013lx (0.0008lx in black and white). This guarantees surveillance coverage even when lighting at the scene is very poor.

100% MADE IN VIDEOTECH

Videotec guarantees the extreme robustness and reliability of all its “all-in-one products” with hundreds of validation tests. Mechanics, electronics, positioning, networking, software and firmware are developed end-to-end by the internal Videotec team, with total know-how of all the network products offered.

At the heart of Videotec's product development is the concept of cyber-sustainability. To help customers protect their video surveillance systems and keep them secure, Videotec provides constant updates, training and support throughout the lifecycle of its products, regardless of how old the device is or whether it is still for sale.

Thanks to digitally signed firmware, password-restricted access, access control, centralised management of certificates and compliance with ONVIF Security Service specifications, Videotec guarantees that all its IP products will have the highest level of security during data transfer and device access.

MAXIMUS MVX therefore offers the Videotec warranty of being a reliable platform, that is cyber-safe, future-proof and easily integrated with third party products.

TECHNICAL DATA

MECHANICAL

AISI 316L stainless steel construction

External shot peened and electro-polished surfaces

Sunshield

Integrated wiper

Unit weight:

- 8.5kg (18.7lb) (housing with 4m (13ft) armoured multipolar cable)
- 12kg (26.5lb) (housing with 10m armoured multipolar cable)

CABLE GLANDS

Cable entry: 1 hole, 3/4" NPT

Cable gland Ex db 3/4"NPT and 4m/10m (13ft/33ft) preinstalled multipolar armoured cable or with 4m/10m (13ft/33ft) cable tail (for installation with conduit, conduit sealing fitting and conduit not included)

HOUSING'S WINDOW

Material: Thermally tempered glass

Dimensions: 51x41mm (2x1.6in)

Thick: 12mm (0.47in)

ELECTRICAL

Supply voltage/Current consumption

- 24Vac \pm 10%, 2.2A, 50/60Hz
- 24Vdc \pm 5%, 2.2A
- 12Vdc \pm 5%, 3.5A

Heater (Ton 15°C \pm 3°C (59°F \pm 5°F), Toff 22°C \pm 3°C (72°F \pm 5°F))

Armoured cable:

- external diameter = 20.00 \pm 0.50mm (0.79 \pm 0.20in)
- under armour diameter = 15.20mm (0.60in)
- colour: Black RAL 9005

Armoured cable composition:

- 3 x 2.5mm²
- 7 x 0.34mm²
- 4 x 2 x 0.22mm² (cat. 5E)

Cable tail composition:

- 3 x 2.5mm², rated external diameter = 8.7mm (0.34in)
- 7 x 0.34mm², rated external diameter = 6.4mm (0.25in)
- 4 x 2 x 0.21mm², (cat. 5E), rated external diameter = 6.7mm (0.26in)

NETWORK

Ethernet connection: 100 Base-TX

Connector: RJ45

CYBERSECURITY

Digitally signed firmware

Password restricted access (HTTP digest)

Support of various user access levels

Control of accesses IEEE 802.1X

HTTPS cryptography using TLS1.0, TLS1.1, TLS1.2 and TLS1.3

Centralised certificate management

Complies with ONVIF Security Service specifications

VIDEO

Video encoder

- Communication protocol: ONVIF, Profile Q, Profile S and Profile T
- Device configuration: TCP/IPv4-IPv6, UDP/IPv4-IPv6, HTTP, HTTPS, NTP, DHCP, WS-DISCOVERY, DSCP, IGMP (Multicast), SOAP, DNS
- Streaming: RTSP, RTCP, RTP/IPv4-IPv6, HTTP, Multicast
- Video compression: H.264/AVC, MJPEG, MPEG4
- 3 independent video streams Full HD
- Image resolution: from 320x180pixel up to 1920x1080pixel in 8 steps
- Selectable frame rate from 1 to 60 images per second (fps)
- Web Server
- Motion Detection
- QoS: Differentiated DSCPs for streaming and device management
- SNMP and NTCIP protocols

I/O INTERFACE

I/O alarm board

- Alarm inputs: 1
- Relay outputs: 1 (1A, 30Vac/60Vdc max)

CAMERAS

SONY FCB-EV7520 Day/Night Full HD 30x

Resolution: Full HD 1080p (1920x1080)

Image Sensor: 1/2.8" Exmor™ R CMOS sensor

Effective Pixels: approx. 2.13 Megapixels

Minimum Illumination:

- Colour: 0.0013lx (50 IRE, High sensitivity on)
- B/W: 0.0008lx (30 IRE, High sensitivity on)

Focal length: from 4.3mm (wide) up to 129mm (tele)

Zoom: 30x (360x with digital zoom)

Iris: from F1.6 up to F14 (Auto, Manual)

Horizontal Viewing Angle: from 63.7° (wide end) up to 2.3° (tele end)

Vertical Viewing Angle: from 38.5° (wide end) up to 1.3° (tele end)

Shutter speed: from 1/1s up to 1/10000s (Auto, Manual)

White balance: Auto, Auto Tracing, Indoor, Outdoor, Manual, Outdoor Auto, Sodium Lamp (Fix/Auto/Outdoor Auto)

Gain: from 0dB up to 50.0dB (Auto, Manual)

Wide Dynamic Range: 120dB

Focus System: Auto (PTZ Trigger, Full Auto), Manual

Picture Effects: E-flip

Noise removal (2D, 3D): Off, On (from level 1 up to level 5)

Exposure Control: Auto, Manual, Priority (Shutter priority, Iris priority, Brightness priority)

De-fog: Off, Low, Mid, High

Dynamic masking of privacy zones: maximum 24 masks settable, maximum 8 simultaneously displayable

Indoor Flicker Reduction

Gain Limit: from 10.7dB up to 50dB

High sensitivity: On/Off

Backlight Compensation: On/Off

Auto Slowshutter: On/Off

Exposure compensation: Off, On (from -10.5dB up to +10.5dB)

Sharpness: from level 0 up to level 15

High Light Compensation (HLC): Off, Low, Mid, High, Masking Level (Off, On, from level 1 up to level 15)

Digital image stabilization: On/Off

ENVIRONMENT

For indoors and outdoors installation

Operating temperature:

- Cold start from -40°C (-40°F) up to +65°C (149°F)
- Running from -50°C (-58°F) up to +65°C (149°F)

Relative humidity: from 5% up to 95%

CERTIFICATIONS

Electrical safety (CE): EN60950-1, IEC60950-1, EN62368-1, IEC62368-1

Electromagnetic compatibility (CE): EN61000-6-4, EN61000-3-2, EN61000-3-3, EN50130-4, EN55032 (Class A)

RoHS (CE): EN50581

Outdoor installation (CE): EN60950-22, IEC60950-22

IP protection degree (EN/IEC60529): IP66, IP67, IP68 (2 hours, 5m (16ft)), IP69

Vibration test: EN50130-5, EN60068-2-6

UL certification (UL60950-1, CAN/CSA C22.2 No. 60950-1-07, UL62368-1, CAN/CSA C22.2 No. 62368-1-14): cULus Listed

Electromagnetic compatibility (North America): FCC part 15 (Class A), ICES-003 (Class A)

Level of protection Type (UL50E): 4X, 6P

RCM (Australian and New Zealand Regulatory Compliance Mark)

NDAA compliant

CERTIFICATIONS - EXPLOSION-PROOF APPLICATIONS

ATEX (EN 60079-0+A11, EN 60079-1, EN 60079-31)

IECEX (IEC 60079-0, IEC 60079-1, IEC 60079-31)

EAC EX (TR CU 012/2011)

INMETRO (ABNT NBR IEC 60079-0 + Errata 1, ABNT NBR IEC 60079-1 + Errata 1, ABNT NBR IEC 60079-31)

KCs (Employment and labor department 2016-54), cable tail versions

ETL listed for USA (UL 60079-0, UL 60079-1, UL 60079-31), cable tail versions

ETL listed for Canada (CAN/CSA-C22.2 NO. 60079-0, CAN/CSA-C22.2 NO. 60079-1, CAN/CSA-C22.2 NO. 60079-31), cable tail versions

For further details on certifications and markings, consult the relevant table.

CERTIFICATIONS - MARINE APPLICATIONS

Lloyd's Register Marine Type Approval certification (only if used with the filter accessory FM1010):

- Test Specification Number 1 (ENV1, ENV2, ENV3, ENV5)

Electromagnetic compatibility: EN60945

Salty fog resistance: EN60068-2-52

Tested at 70°C (158°F) for 16 hours in compliance with EN60068-2-2

ACCESSORIES

WASEX2T4AT	Tank 10l (2.6gal) with integrated manual pump controlled by ATEX certified solenoid valve, delivery head up to 20m (66ft) max, IN 24Vac/Vdc
WASEX2T4GOR	Tank 10l (2.6gal) with integrated manual pump controlled by EAC EX certified solenoid valve, delivery head up to 20m (66ft) max, IN 24Vac/Vdc
WASEX2T4IN	Tank 10l (2.6gal) with integrated manual pump controlled by INMETRO certified solenoid valve, delivery head up to 20m (66ft) max, IN 24Vac/Vdc
MBX1MAA	Explosion-proof communication box in stainless steel, IN 230Vac, with EMC filter for marine certification
MBX2MAA	Explosion-proof communication box in stainless steel, IN 24Vac, with EMC filter for marine certification
MBX3MAA	Explosion-proof communication box in stainless steel, IN 120Vac, with EMC filter for marine certification
MBA1SSA	Explosion-proof communication box in aluminium, IN 230Vac
MBA2SSA	Explosion-proof communication box in aluminium, IN 24Vac
MBA3SSA	Explosion-proof communication box in aluminium, IN 120Vac
OCTEXP3/4C	Conduit cable gland nickel-plated brass 3/4" NPT IECEX-ATEX- c CSA us - EAC Ex (operating temperature: from -60°C (-76°F) up to +80°C (+176°F))
FM1010	EMC filter for Marine certification

BRACKETS AND ADAPTORS

NXWBS1	AISI 316L stainless steel wall bracket with joint
MHXWFWCA	AISI 316L stainless steel ball joint
NXFWBT	AISI 316L stainless steel parapet mounting bracket
NXCOLD	AISI 316L stainless steel pole adapter module
NXCW	AISI 316L stainless steel corner adapter module
NXWTU	AISI 316L stainless steel adapter module for oblique surfaces

PACKAGE

Model Number	Weight	Dimensions (WxHxL)	Master carton
MVXHD2xxxxxxx8	12.5kg (28lb)	60x30x60cm (24x12x24in)	-

MAXIMUS MVX RANGE - CERTIFICATIONS AND MARKINGS (VERSIONS WITH ARMoured CABLE)

Certification	Marking	Ambient temperature
ATEX	Ⓜ II 2 G Ex db IIC T5 Gb Ⓜ II 2 D Ex tb IIIC T100°C Db IP66/IP68	-60°C ≤ Ta ≤ +65°C
	Ⓜ II 2 G Ex db IIC T6 Gb Ⓜ II 2 D Ex tb IIIC T85°C Db IP66/IP68	-60°C ≤ Ta ≤ +55°C
IECEX	Ex db IIC T5 Gb Ex tb IIIC T100°C Db IP66/IP68	-60°C ≤ Ta ≤ +65°C
	Ex db IIC T6 Gb Ex tb IIIC T85°C Db IP66/IP68	-60°C ≤ Ta ≤ +55°C
INMETRO	Ex db IIC T5 Gb Ex tb IIIC T100°C Db IP66/IP68	-60°C ≤ Ta ≤ +65°C
	Ex db IIC T6 Gb Ex tb IIIC T85°C Db IP66/IP68	-60°C ≤ Ta ≤ +55°C
EAC Ex	1Ex d IIC T5 Gb X Ex tb IIIC T100°C Db X	-60°C ≤ Ta ≤ +65°C
	1Ex d IIC T6 Gb X Ex tb IIIC T85°C Db X	-60°C ≤ Ta ≤ +55°C

MAXIMUS MVX RANGE - CERTIFICATIONS AND MARKINGS (CABLE TAIL VERSIONS, FOR INSTALLATION WITH CONDUIT)

Certification	Marking	Ambient temperature
ATEX	Ⓜ II 2 G Ex db IIC T5 Gb Ⓜ II 2 D Ex tb IIIC T100°C Db IP66/IP68	-50°C ≤ Ta ≤ +65°C
	Ⓜ II 2 G Ex db IIC T6 Gb Ⓜ II 2 D Ex tb IIIC T85°C Db IP66/IP68	-50°C ≤ Ta ≤ +55°C
IECEX	Ex db IIC T5 Gb Ex tb IIIC T100°C Db IP66/IP68	-50°C ≤ Ta ≤ +65°C
	Ex db IIC T6 Gb Ex tb IIIC T85°C Db IP66/IP68	-50°C ≤ Ta ≤ +55°C
INMETRO	Ex db IIC T5 Gb Ex tb IIIC T100°C Db IP66/IP68	-50°C ≤ Ta ≤ +65°C
	Ex db IIC T6 Gb Ex tb IIIC T85°C Db IP66/IP68	-50°C ≤ Ta ≤ +55°C
KCs	Ex d IIC T5 Ex tb IIIC T100°C	-50°C ≤ Ta ≤ +65°C
	Ex d IIC T6 Ex tb IIIC T85°C	-50°C ≤ Ta ≤ +55°C
EAC Ex	1Ex d IIC T5 Gb X Ex tb IIIC T100°C Db X	-50°C ≤ Ta ≤ +65°C
	1Ex d IIC T6 Gb X Ex tb IIIC T85°C Db X	-50°C ≤ Ta ≤ +55°C
Hazardous Location America	Class I Zone 1 AEx db IIC T5 Gb Zone 21 AEx tb IIIC T100°C Db Class I Div 2 Group A, B, C & D T5 Class II Div 2 Group F & G T100°C	-50°C ≤ Ta ≤ +65°C
	Class I Zone 1 AEx db IIC T6 Gb Zone 21 AEx tb IIIC T85°C Db Class I Div 2 Group A, B, C & D T6 Class II Div 2 Group F & G T85°C	-50°C ≤ Ta ≤ +55°C
Hazardous Location Canada	Ex db IIC T5 Gb Ex tb IIIC T100°C Db Class I Div 2 Group A, B, C & D T5 Class II Div 2 Group F & G T100°C	-50°C ≤ Ta ≤ +65°C
	Ex db IIC T6 Gb Ex tb IIIC T85°C Db Class I Div 2 Group A, B, C & D T6 Class II Div 2 Group F & G T85°C	-50°C ≤ Ta ≤ +55°C

MAXIMUS MVX WITH SONY FCB-EV7520 CAMERA - CONFIGURATION OPTIONS WITH CABLE GLAND AND SHIELDED CABLE

	Voltage	Camera		Connections	Video Output	Model	
MXHD	2 12-24Vdc/ 24Vac	20 SONY FCB-EV7520 camera, FULL HD 1080p, 30x	W With wiper	A Cable gland Ex d 3/4" NPT and 4m (13ft) armoured cable	Z IP H.264/AVC control, ONVIF protocol Profile Q, Profile S and Profile T	00 T5 -60°C/+65°C	B
				B Cable gland Ex d 3/4" NPT and 10m (32.8ft) armoured cable		02 T6 -60°C/+55°C	

MAXIMUS MVX WITH SONY FCB-EV7520 CAMERA - CONFIGURATION OPTIONS WITH CABLE TAIL (FOR INSTALLATION WITH CONDUIT, CONDUIT SEALING FITTING AND CONDUIT NOT INCLUDED)

	Voltage	Camera		Connections	Video Output	Model	
MXHD	2 12-24Vdc/ 24Vac	20 SONY FCB-EV7520 camera, FULL HD 1080p, 30x	W With wiper	F 4m (13ft) cable tail	Z IP H.264/AVC control, ONVIF protocol Profile Q, Profile S and Profile T	01 T5 -50°C/+65°C	B
				G 10m (32.8ft) cable tail		03 T6 -50°C/+55°C	

TECHNICAL DRAWINGS

The indicated measurements are expressed in millimetres.

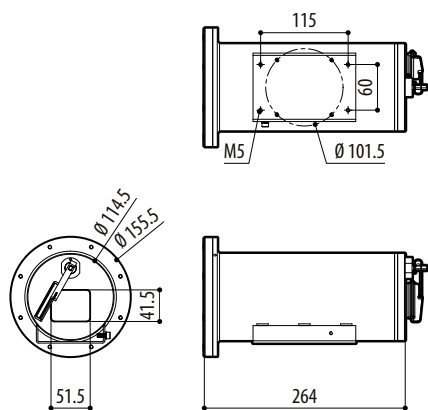

MAXIMUS MVX