

MAIN FEATURES

Indoor/Outdoor installations

Extruded aluminium body

Hinged, removable body

Double mounting option: regular or feed-through brackets

Weatherproof Standard IP66/IP67

DESCRIPTION

This housing is suitable for a variety of cameras (1/2", 1/3" and 1/4") equipped with a wide range of lenses. Constructed from extruded and die-cast aluminium.

Its weatherproof feature is ensured by the EPDM-rubber gaskets and by 3 cable glands. The use of the cable management bracket gives a total vandal-proof protection to the power and video cables. A wide range of accessories is available: sunshield, normal and fan-assisted heater, blower and camera power supply.

Further, it is also possible to install a blower with an air filter replacing one of the cable glands. The accessories are supplied factory installed or as a simple upgrade kit.



HEB



HEB + WBOVA2

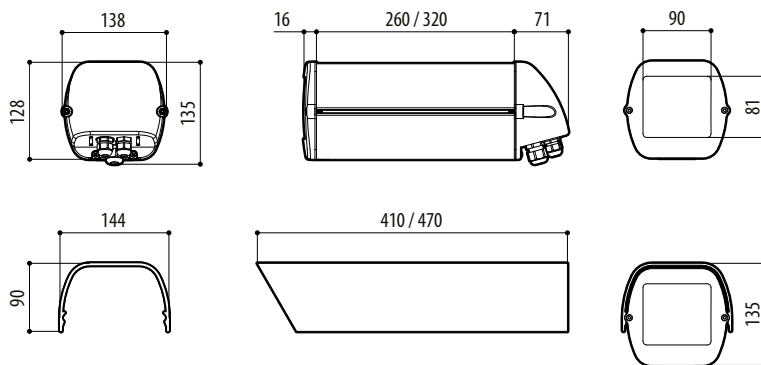

HEB

mm 1:10

AVAILABLE MODELS					
Code	Sunshield	Heater 115/230Vac	Heater 12Vdc/24Vac	Fan assisted heater 24Vac	Max consumption
HEB26D0A000B					
HEB26K0A000B	•				
HEB26K1A000B	•	•			40W
HEB26K2A000B	•		•		20W
HEB32D0A000B					
HEB32K0A000B	•				
HEB32K1A000B	•	•			40W
HEB32K2A000B	•		•		20W
HEB32K2A015B	•			•	24W

TECHNICAL DATA

GENERAL

Aluminium back and front cover plates
 Extruded aluminium body, external slide and sunshield
 Epoxypolyester powder painting, RAL9002 colour
 Stainless steel external screws
 Supplied with instruction manual, desiccant bag, accessories for camera and lens mounting

MECHANICAL

3xM16 cable glands
 Glass window (WxH): 90x81mm (3.5x3.2in)
 Internal usable area (WxH): 90x85mm (3.5x3.3in)
 Internal usable length without accessories
 HEB26 260mm (10.2in)
 HEB32 320mm (12.6in)
 Internal usable length with heater and/or power supply, or heater and/or blower
 HEB26 190mm (7.5in)
 HEB32 250mm (9.8in)

ELECTRICAL

Heater Ton 15°C±3°C (59°F±5°F) Toff 22°C±3°C (71°F±5°F)
 • IN 12Vdc/24Vac, consumption 20W max
 • IN 115/230Vac, consumption 40W max
 Blower with thermostat and air filter, Ton 35°C±3°C (95°F±5°F) Toff 20°C±3°C (71°F±5°F) and back cover
 • IN 12Vdc, consumption 4W max
 • IN 24Vac, consumption 4W max
 • IN 230Vac, consumption 4W max, complete with voltage transformer

Not compatible with bracket with internal cable channel.

PACKAGE

Code	Unit weight		Package weight		Package dimensions (WxHxL)		Master carton
	kg	lb	kg	lb	cm	in	unit
HEB26K	2.7	5.9	3.0	6.6	15.5x14.0x43.0	6.1x5.5x16.9	10
HEB32K	3.2	7.0	3.5	7.7	16.5x15.5x49.0	6.4x6.1x19.3	10

Camera power supply

- IN 100-240Vac - OUT 12Vdc, 50/60 Hz, 1A
- IN 230Vac - OUT 24Vac, 50/60Hz, 400mA

ENVIRONMENT

Indoor / Outdoor
 Operating temperature with heater: -20°C / +60°C (-4°F / +140°F)
 Resistant to salty fog until 1000 hours (according to ISO9227)

CERTIFICATIONS

CE EN61000-6-3, EN60065, EN50130-4
 IP66/IP67 EN60529 with cable glands
 IP66/IP67 EN60529 with special gaskets and bracket with internal cable channel
 IP55 EN60529 with bracket with internal cable channel

ACCESSORIES

OHEBS26A000	Sunshield for HEB26
OHEBS32A000	Sunshield for HEB32
OHEH01B	Heater 12Vdc/24Vac
OHEH02B	Heater 115/230Vac
OHEBVF1	Blower with thermostat air filter IN 12Vdc
OHEBVF2	Blower with thermostat air filter IN 24Vac
OHEBVF3	Blower with thermostat air filter IN 230Vac
OHEPS01B	Wide range camera power supply IN 100-240Vac - OUT 12Vdc, 1A
OHEPS02B	Camera power supply IN 230Vac - OUT 24Vac, 400mA
OWBIP2	Kit special gaskets (3xM16) to allow protection IP66/IP67 for WBOVA2 and WCM4A2 brackets
OHEGGB	Weatherproof junction box IP55

BRACKETS AND ADAPTORS

WBJA	Wall bracket with ball joint
WBMA	Wall bracket with ball joint
WBOVA2	Wall bracket with internal cable channel
WBOV3A2	Wall bracket with internal cable channel, support plate and integrated junction box
WCM3A	Ceiling bracket with ball joint
WCM5A	Ceiling bracket with ball joint
WCM4A2	Ceiling bracket with internal cable channel
WFWCA	Column mount with ball joint

RELATED PRODUCTS

PTH300	Pan&Tilt series
PTH900	Pan&Tilt series

SPARE PARTS

DOTHE01	Spacers for camera and lens
OHEBMAN	Cable glands, gaskets and screws kit
OHBCFA04	Front cover with screws and gaskets
OHBFPO4B	Back cover with cable glands, screws and gaskets