



PRODUCT SPECIFICATION

MODEL: V814AWM

PRODUCT CODE: 6044

DESCRIPTION: ADJUSTABLE WALL MOUNT

- Full 360° horizontal and ±75° vertical movement
- Attractive style and finish
- Versatile camera mounting

The V814AWM Adjustable Wall Mount is designed to support camera/housing combinations up to 25 pounds (11.4 kg). The adjustable head allows for full 360-degree rotation and varying tilt angles.

The V814AWM is a light-duty adjustable wall mount constructed of painted cast aluminum. It is suitable for indoor or outdoor installations. The mounting flange is attached to the wall using three No. 8 screws. The camera is attached to the mount using the three available holes on the adjustable head.

TECHNICAL INFORMATION

MECHANICAL

- Application: Indoor or outdoor.
- Flange Mounting: Three No.8 screws into wall or vertical structure.
- Camera Mounting: Hole pattern on the adjustable head.
- Type: Adjustable.

NOTES	SPEC NO.	REV.	SEC.
	938	698	7

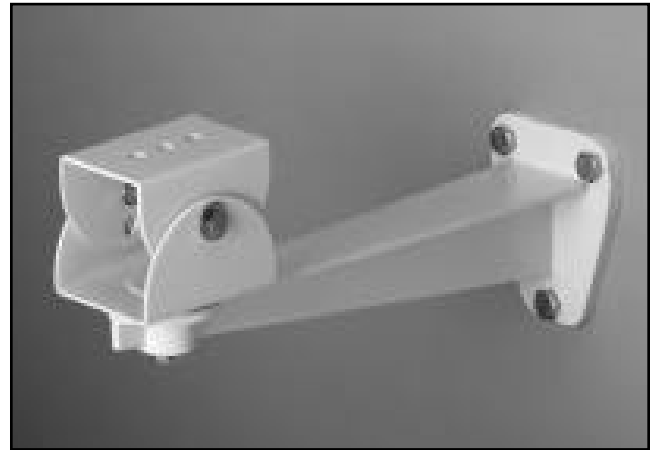

V814AWM ADJUSTABLE WALL MOUNT

Angular Movement: Vertical: ±75°.
Horizontal: 360°.

Load Rating: 25 lb (11.4 kg).

Dimensions: Height (H): 5.4 in. (13.6 cm).
Width (W): 2.9 in. (7.4 cm).
Depth (D): 11.6 in. (29.5 cm).

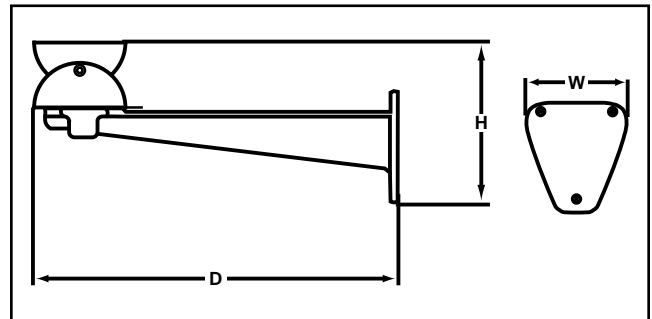

CONTRACTORS' SPECIFICATION

ADJUSTABLE WALL MOUNT

The wall mount shall be a light-duty adjustable indoor/outdoor unit. It shall be of die-cast aluminum construction. It shall have a load rating of 25 lb (11.4 kg). Height and width shall not exceed 5.4 in. (13.6 cm) and 2.9 in. (7.4 cm), respectively. Depth shall not exceed 11.0 inches (27.9 cm). Weight shall not exceed 1.5 lb (0.7 kg). The head shall be manually adjustable over a pan range of 360° and a tilt range of ±75°.

The wall mount shall be Vicon's Model V814AWM.

Product specifications subject to change without notice.
Copyright © 1998 Vicon Industries Inc. All rights reserved.

Vicon part number 8006-7938-00-00
Vicon and its logo are registered trademarks of Vicon Industries Inc.

Weight: 1.5 lb (0.7 kg).

Construction: Cast aluminum.

Finish: Primed and painted light beige.

Shipping Dimensions: Height: 4.3 in. (11.0 cm).
Width: 3.4 in. (8.6 cm).
Depth: 11.8 in. (30.0 cm).

Shipping Weight: 1.7 pounds (0.8 kg).

Shipping Volume: 0.1 ft³ (0.003 m³).

ENVIRONMENTAL

Storage
Temperature Range: -40 to 150° F (-40 to 60° C).

Storage
Humidity Range: 0 to 90% relative, noncondensing.