



SURVEYORVFT

SVFT-PR-P/SVFT-PR-WMA Pipe Mount and Wall Mount for the Pressurized Housing Version of SurveyorVFT Camera Dome

- **Rugged, cast-metal mounts designed for outdoor environments**
- **Mount design maximizes assembly/service accessibility**
- **Connection flange is compatible with existing Vicon mounts**

The SVFT-PR-P Pipe Mount and SVFT-PR-WM Wall Mount are designed to mount the pressurized housing version of the SurveyorVFT Camera Dome. They are heavy-duty mounts, constructed of painted aluminum. They are suitable for indoor or outdoor installations. The pipe mount is bolted to the top of the housing and can be mounted to several SurveyorVFT mounts or coupled

to a pre-installed section of 1-1/2 in. (38 mm) diameter American National Standard Tapered Pipe Thread (NPT) pipe by removing the nipple. The wall mount is bolted to the top of the housing and flange mounted to the wall. Cables can be routed through the wall mount or outside the mount's flange and through the cable access hole. The wall mount's flange is compatible with the V24CMB Corner Mounting Bracket and the V20A Pole Mounting Adapter.

ASSOCIATED EQUIPMENT AND ACCESSORIES

Model Pressurized SurveyorVFT Camera Dome System: A pressurized, environmentally protected, version of the SurveyorVFT Camera Dome. It is a compact high-speed dome unit with an integral receiver, pan/tilt drive and camera/lens module. Refer to Product Specifications V004-1X.

Model SVFT-UPM Parapet Mount, Product Code 8348: Mounts SurveyorVFT to a roof parapet. Product Specification V138.

Model SVFT-URM Roof Mount, Product Code 8349: Mounts SurveyorVFT to a roof. Product Specification V139.

Model SVFT-UWM Wall Mount, Product Code 8352: Mounts SurveyorVFT to a wall. Product Specification V140.

Model SVFT-UCM Ceiling Mount, Product Code 8351: Mounts SurveyorVFT pendant to the ceiling. Product Specification V142.

Model SVFT-UCP Ceiling Panel, Product Code 8373: Mounts SurveyorVFT in-ceiling into a ceiling. Product Specification

Model V24CMB Corner Mounting Bracket, Product Code 1971: Enables the wall mount to be mounted to a building corner. Refer to Product Specification 605.

Model V20A Pole Mount Adapter, Product Code 3691: Enables the wall mount to be attached to a pole. Refer to Product Specification 532.

**TECHNICAL SPECIFICATIONS
DIVISION 13 - SPECIAL CONSTRUCTION
SECTION 137__ - SECURITY CCTV SYSTEM**

SECURITY SYSTEM

PART 2 - PRODUCTS

2.01 GENERAL

- A. All equipment and materials used shall be standard components, regularly manufactured, regularly utilized in the manufacturer's system.
- B. All systems and components shall have been thoroughly tested and proven in actual use.
- C. All systems and components shall be provided with the availability of a toll free 24-hour technical support phone number from the manufacturer. The phone number shall allow for immediate technical assistance from either the dealer/installer or the end user at no charge.
- D. All systems and components shall be provided with an explicit manufacturer warranty.

2.02 PIPE MOUNT FOR THE PRESSURIZED HOUSING VERSION OF THE CAMERA DOME

- A. The pipe mount shall be a heavy-duty indoor/outdoor unit.
- B. The pipe mount shall be fitted to a ceiling or horizontal surface using a 1-1/2 in. (38 mm) I.D., American National Standard Tapered Pipe Thread (NPT) pipe.
- C. It shall connect to the pressurized housing also using a four (4) bolt flange design.
- D. The pipe mount shall have sufficient load rating to support the pressurized housing version of the camera dome system.
- E. The pipe mount shall have the following mechanical specifications:
 - 1. Mounting: Ceiling or horizontal structure.
 - 2. Dimensions: Height: 3.0 in. (76 mm)
Length/Width: 4.4 in. (111 mm)
 - 3. Weight: 1.0-lb (0.45 kg).
 - 4. Construction: Cast aluminum. Stainless steel hardware.
 - 5. Color: White.

The pipe mount shall be Vicon Industries Model SVFT-PR-P.

2.03 WALL MOUNT FOR THE PRESSURIZED HOUSING VERSION OF THE CAMERA DOME

- A. The wall mount shall be a heavy-duty indoor/outdoor unit.
- B. The wall mount shall be fitted to a wall or vertical surface using a four (4) bolt flange.
- C. It shall connect to the pressurized housing also using a four (4) bolt flange design.
- D. The wall mount shall have sufficient load rating to support the pressurized dome system.
- E. It shall have a cable access hole and include a liquid tight fitting for outdoor applications.
- F. The wall mount shall have the following mechanical specifications:
 - 1. Mounting: Wall or vertical structure.
 - 2. Dimensions: Height: 9.4 in. (239 mm).
Width: 6.6 in. (167 mm).
Depth: 15.2 in. (386 mm).
 - 3. Weight: 5.25-lb (2.4 kg).
 - 4. Construction: Cast aluminum. Stainless steel hardware.
 - 5. Color: White.

The wall mount shall be Vicon Industries Model SVFT-PR-WMA.

MECHANICAL

(SVFT-PR-P Pipe Mount)

Application: Indoor or outdoor, specifically designed for the SurveyorVFT Pressurized Housing.

Mounting Surface: Ceiling or horizontal structure.

Mounting Thread: 1-1/2 in. (38 mm) I.D. American National Standard Tapered Pipe Thread (NPT) pipe.

Dimensions: See Figure 1.
Width/Length: 4.4 in. (111 mm).
Height: 3.0 in. (76 mm).

Weight: 1.0 lb (0.45 kg).

Construction: Cast aluminum.

Finish/Color: Painted white.

Shipping Dimensions: Length: 7.0 in. (178 mm).
Width: 6.5 in. (165 mm).
Height: 5.0 in. (127 mm).

Shipping Weight: 1.5 lb (0.68 kg).

Shipping Volume: 0.1 ft³ (0.003 m³).

(SVFT-PR-WMA)

Application: Indoor or outdoor, specifically designed for the SurveyorVFT Pressurized Housing.

Mounting: Wall or vertical structure.

Cable Access: Through the mount or through the provided cable access hole. A liquid tight fitting is provided to route cable conduit through in order to keep the mount's interior and cables dry.

Dimensions: See Figure 1.
Height: 9.4 in. (239 mm).
Width: 6.6 in. (167 mm).
Depth: 15.2 in. (386 mm).

Weight: 5.25 lb (2.4 kg).

Construction: Cast aluminum.

Finish/Color: Painted white.

Shipping Dimensions: Height: 14.6 in. (37.1 cm).
Width: 7.3 in. (18.5 cm).
Depth: 17.3 in. (44.0 cm).

Shipping Weight: 6.6 lb (3.0 kg).

Shipping Volume: 1.06 ft³ (0.03 m³).

**ENVIRONMENTAL
(for both SVFT-PR-P and SVFT-PR-WMA)**

Storage

Temperature Range: -40 to 150° F (-40 to 60° C).

Storage

Humidity Range: 0 to 90% relative, noncondensing.

SVFT-PR-P Dimensions

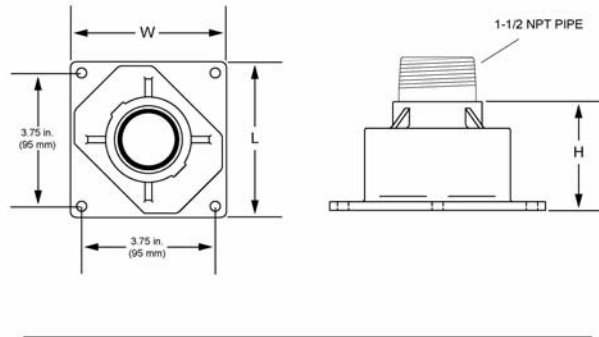

SVFT-PR-WMA Dimensions

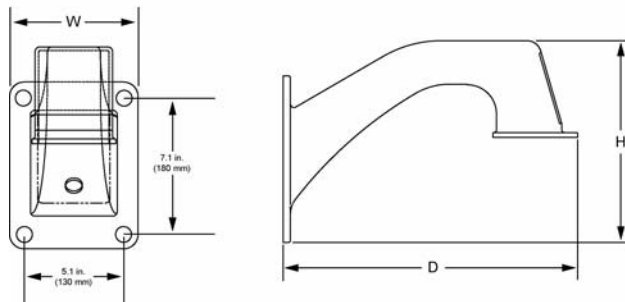

Figure 1