

High Physical Security

1350kg (3000lb) holding force
Impact tested 500j

Low Profile

Protrudes only 40mm into door headroom

Side Load Operation

Operates and releases freely with up to 545kg (1200lb) of side load

Anti-tamper

Deadlock protected against tampering

Door Position/Latch Monitor

ES7000 Series only

Self Latching

Will self latch without power for fire applications

Robust Construction

Stainless Steel lock components and strike plate

Multiple Orientation

Can be mounted vertically or horizontally

Multi Voltage

Automatic selection of 12 or 24vDC with back EMF and reverse polarity protection

Low Current Consumption

Volts	Current - Activate	Current - Hold (after 0.5 secs)
12vDC	750mA	375mA
24vDC	375mA	187mA

Finishes

Standard Silver PPC
Specials on request

Options

Concealed fixing kit for striker

Approvals

UL1034 (highest levels) Tested to 1⁻⁶ cycles
Australian 4 Hour Fire Rating
CE - BS EN 50081 -1 and BS EN 50082-1



The Trimec ES700/7000 surface locks have been designed for the Specifier and Installer looking for an alternative to a surface mount direct pull magnetic lock. Offering Fail Open/PTL or Fail Secure/PTO operation in a compact low profile lock case which does not protrude excessively (40mm) into the head height of the door opening. The ES700/7000 offers approximately three times the holding force of the largest direct pull magnets and with it's high preload (side load) capability and a 4 hour Fire Rating they are ideal for fire door applications and anywhere a high security surface mount solution is required.

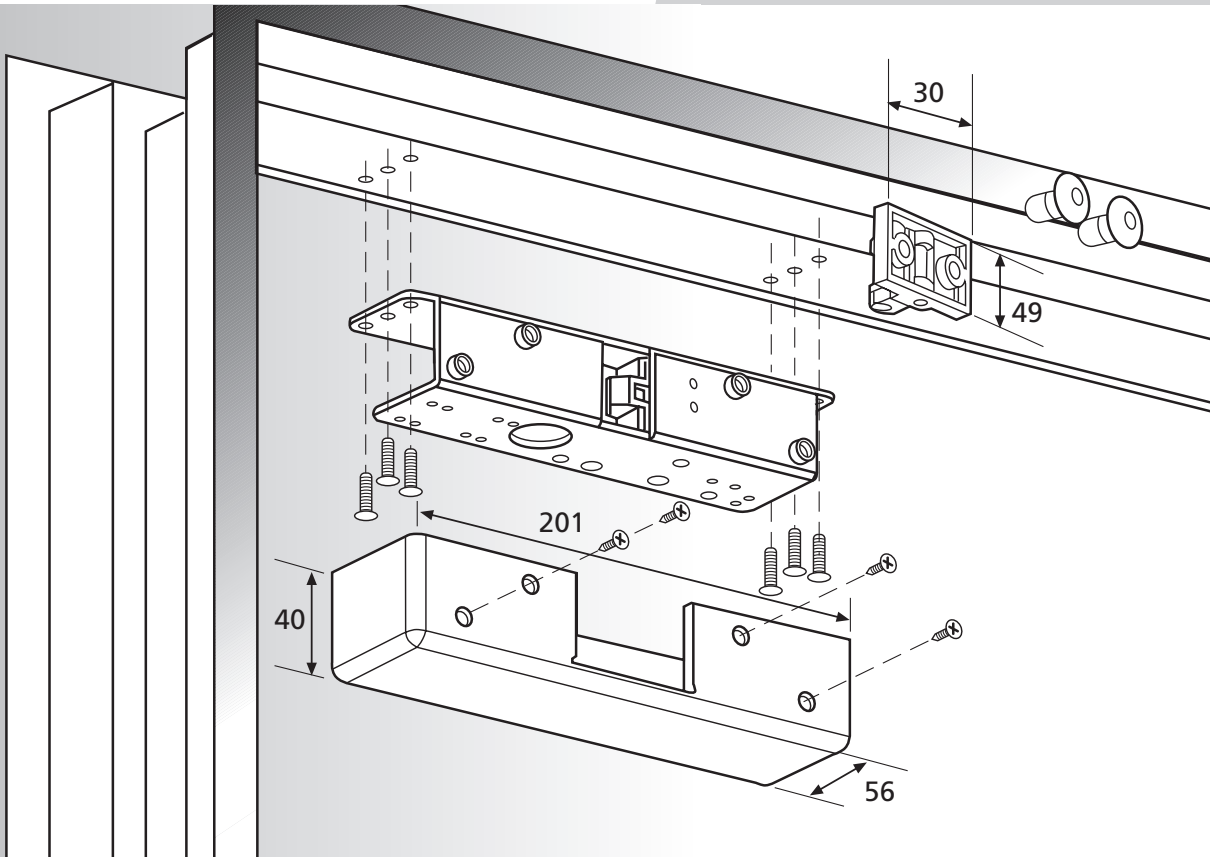

Technical Data

Electrical

750mA @ 12vDC for 0.5 secs - 375mA thereafter for continuous use
 375mA @ 24vDC for 0.5 secs - 187mA thereafter for continuous use
 Back EMF and reverse polarity protected
 Multivoltage - Auto-selecting 12 or 24vDC

Monitoring ES7000 only

Door/Latch - 3 amp NO/NC microswitch

Dimensions

Lock case - 201mm (L) x 56mm (W) x 40mm (D)

Environment

Operational temperature range -20° to +60°

Installation

FOR CORRECT OPERATION OF THE ES700/7000 - POWER MUST BE APPLIED USING SUPPLIED INLINE POWER CONDITIONER (ES71P)

A metal template is provided for accuracy. Under no circumstances should the ES700/7000 be used as a door stop.

General Information

The ES700/7000 can be installed as either Power to Lock or Power to Open and can be surface mounted either vertically or horizontally. Whilst the locks are designed to have a holding force of 1350kg (3000lb) they are also designed to operate freely without jamming with side loads of 545kg (1200lb) exerted on the door.

Ordering Information

DESCRIPTION	FUNCTION	CODE	FUNCTION	CODE
Surface mounted. All models are PTL/PTO reversible and 12 to 24vDC, complete with PPC surface housing and including Inline Power Conditioner				
Non monitored	Fail Open - Power to Lock	ES701	Fail Secure - Power to Open	ES702
Door position/Latch monitoring	Fail Open - Power to Lock	ES7001	Fail Secure - Power to Open	ES7002
Options				
Concealed fixing kit for striker		ES6CSK		
Spare Parts				
Inline Power Conditioner 12/24v AC/DC		ES71PC		

