

- Side or rear conduit entry holes
- Outdoor rated enclosure designed to meet (IP66)
- Endures the Equivalent of 120lbs of Force
- 540TVL Color, True Day/Night, or WDR Camera Models with UTP option
- 3-Axis Mounting Bracket
- Cast Aluminum Alloy Housing
- 4-in (101mm) Polycarbonate Dome

MLA Vandal Resistant Dome

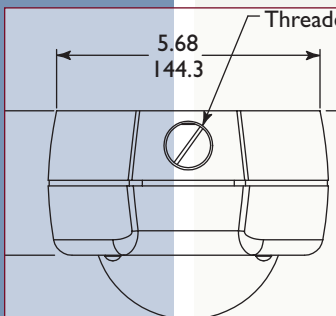
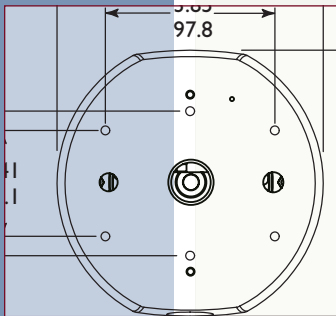
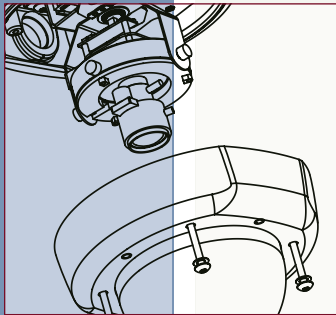

MLA Series

The Aigis MLA series CCTV camera housings offer a vandal resistant solution for indoor or outdoor security applications. These models include a camera and varifocal lens in a cast Aluminum housing (with the strength of 10 gauge steel) and polycarbonate dome.

All units are designed with the installer in mind: the domes are dual voltage (12VDC / 24VAC), a test monitor connection is provided inside the dome (BNC jack), two conduit entry holes are provided (side and top), the domes' two piece construction is easy to install, and the 3-axis camera bracket can be oriented in any direction.

UTP versions are available. Mounting accessories include a pendant mount with ceiling flange and a wall arm. The wall arm can be used with the MT9213 adapter to mount to a pole.

SPECIFICATIONS

CAMERA SPECIFICATIONS			
Model No.	MLA2DN211	MLA2CH211	MLA2WD211
Description	True Day/Night Camera	Color Hi-Res Camera	Wide Dynamic Range Camera
Imager	1/3" Sony Super HAD II CCD	1/3" Sony CCD	1/3" Pixim DPS Sensor
Signal System	NTSC		
Effective Pixels	768 (H) x 494 (V)		720 (H) x 480 (V)
Resolution	540TVL		
Minimum Illumination	0.3Lux/F1.2 (Color) 0.008Lux/F1.2 (B/W)	0.1Lux/F1.2	0.5Lux/F1.2; 0.08Lux/F1.2 (Slow Shutter)
S/N Ratio	>50dB (AGC Off)	>50dB	>50dB
Dynamic Range	-		101dB Typical, 120dB Max
Control Method	-		OSD + Dipswitch
Privacy Masking	-		12 zones (optional)
Day/Night Function	Mechanical IR Cut Filter	-	Electronic D/N
Lens	2.8-11mm Auto-Iris		
White Balance	Auto	Auto	AWB/ATW/Manual Selectable
AWB Range	-		ATW 2,000K to 11,000K
BLC	Auto		-
AGC	Auto	Auto	Adjustable
Gamma Correction	-		Adjustable
Sync Mode	Internal		Internal / Line Lock
Video Output	1.0Vp-p, 75 Ohm		0.8-1.5Vp-p adjustable, 75 Ohm
Power Supply	12VDC/24VAC		
Power Consumption	<4W	<3.5W	<3W

UTP PINOUT

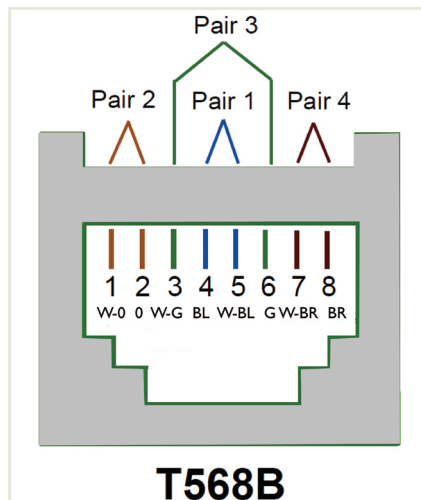

Pin No.	Wire Color	Pair	Utilization
1	White-Orange	2	Video Signal
2	Orange	2	Video Shield
3	White-Green	3	Data +
4	Blue	1	Power - (Neutral)
5	White-Blue	1	Power + (Line)
6	Green	3	Data -
7	White-Brown	4	Power + (Line)
8	Brown	4	Power - (Neutral)

MECHANICAL SPECIFICATIONS

Housing	Construction	Polycarbonate dome (clear) and cast aluminum housing.
	Finish	Standard: Powder coated white finish. Custom finishes available.
	Weight	Unit Weight - 3.3 lbs (1.5kg) / Packaged Weight - 4.2 lbs
Cable Entry		3/4-inch conduit knockout through side or back
Mounting	Surface Mount	Mounts on wall or ceiling using up to four #10 screws.
ENVIRONMENTAL		
Operating Temperature		-4 °F to +122 °F (-20 °C to +50 °C)
Humidity		0% to 90% relative, noncondensing.
Protection Level		Designed to meet IP 66.
Agency Approvals		UL, cUL

MODEL NUMBERS AND DESCRIPTIONS

MLA2CH211	Indoor/outdoor vandal resistant dome, color high-resolution camera, 2.8-11mm varifocal AI/IR lens, 12VDC/24VAC
MLA2WD211	Indoor/outdoor vandal resistant dome, Wide Dynamic Range camera, 2.8-11mm varifocal AI/IR lens, 12VDC/24VAC
MLA2DN211	Indoor/outdoor vandal resistant dome, Day/Night camera mechanical IR cut-filter, 2.8-11mm varifocal AI/IR lens, 12VDC/24VAC
MLA2CH211-U	Same as MLA2CH211 above, except includes UTP converter
MLA2WD211-U	Same as MLA2WD211 above, except includes UTP converter
MLA2DN211-U	Same as MLA2DN211 above, except includes UTP converter

MLA SERIES - DIMENSIONAL DRAWING

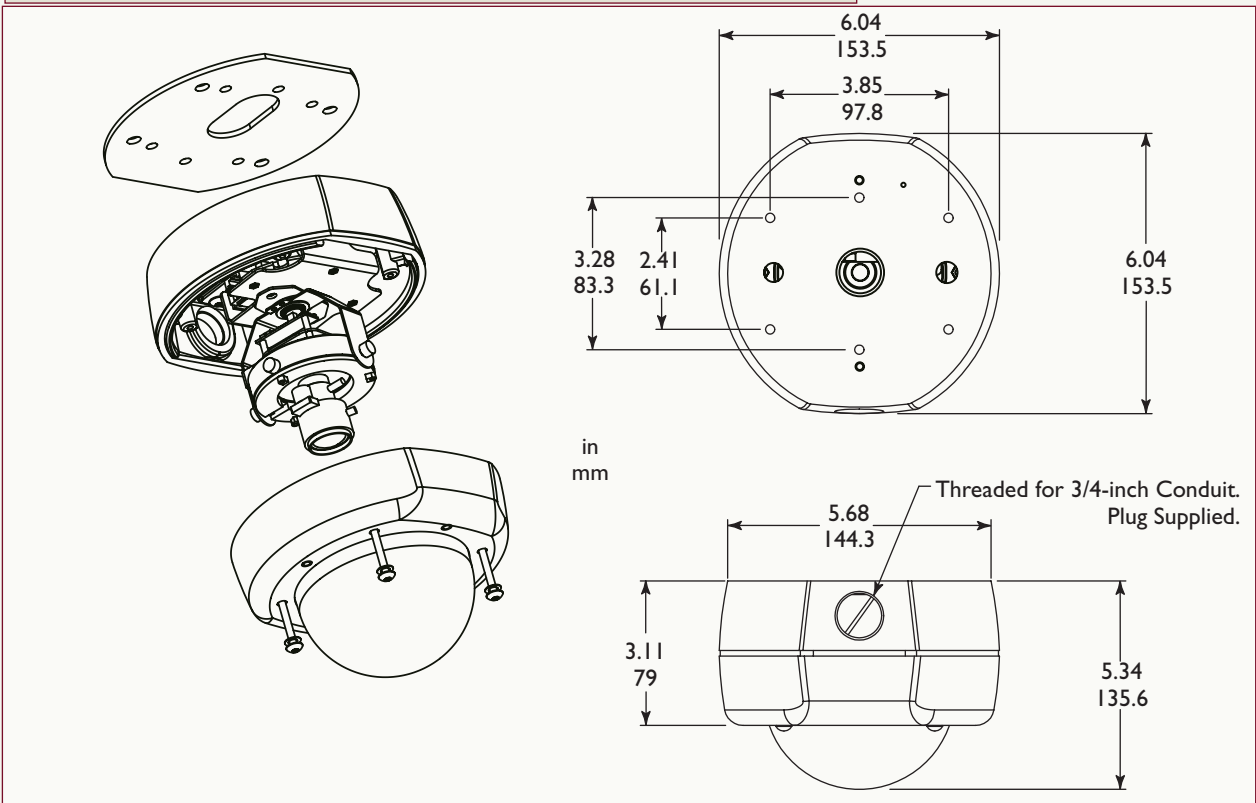

ACCESSORIES

Standard color is white. Stainless steel finish and custom colors available.

Mounting Kits for MLA Series	MLAP	Pipe mounting kit. Includes ceiling flange, gasket and mounting cap with screws.
	MLAW	Wall mounting kit. Includes pendant wall mount, screws and mounting cap with screws, sealing gaskets, and pull seals.

MLAP - MLA PIPE MOUNT ACCESSORY

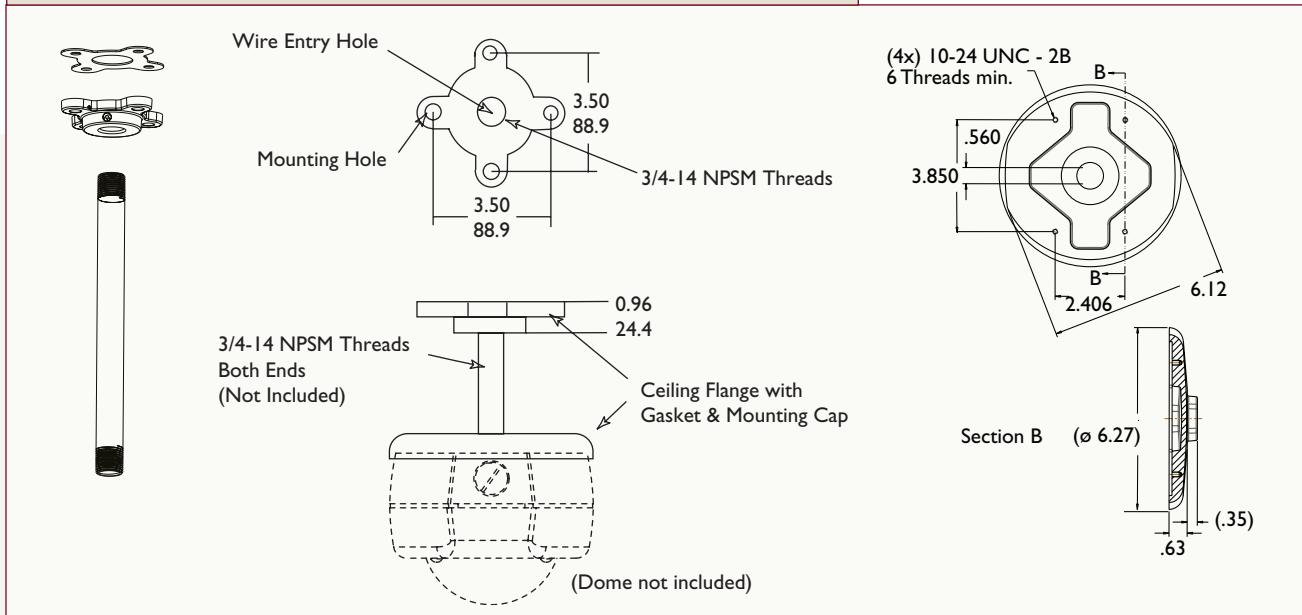

MLA-WM - MLA WALL MOUNT ACCESSORY

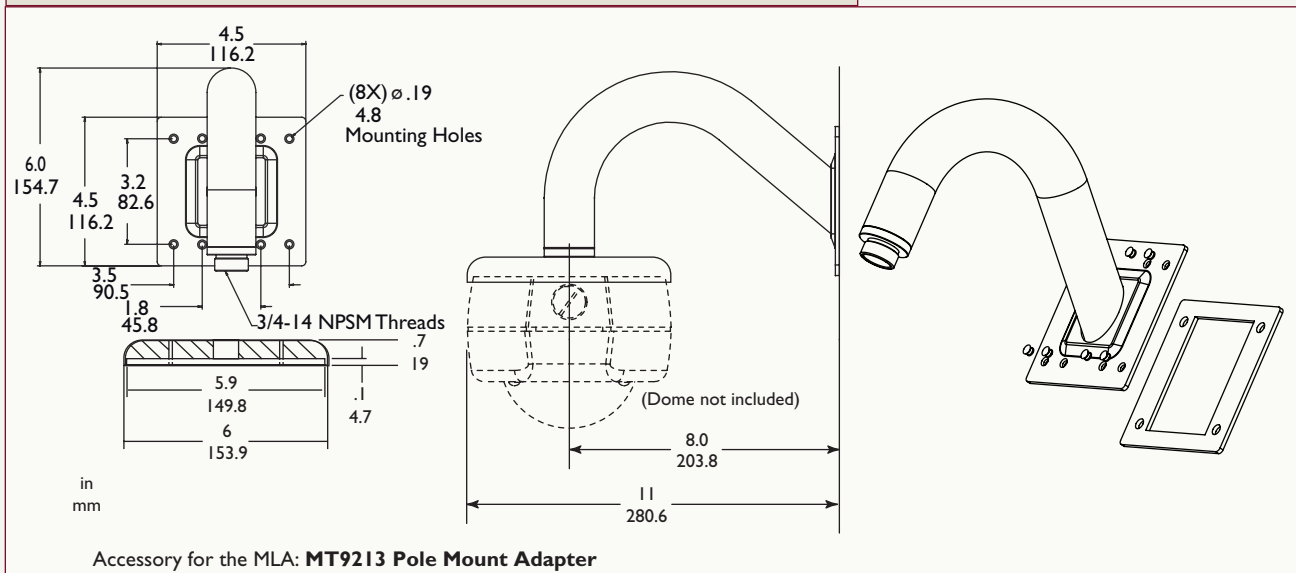

aigis
mechtronics

Now Part of **Linear**[®]
Building On Innovation.

1950 Camino Vida Roble, Suite 150
Carlsbad, CA 92008
Tel: 760.438.7000 800.421.1587
www.aigismech.com • www.linearcorp.com