



**DISCREET CAMERA**

**MONOCHROME**

# CM-310VR

- Outdoor vandal-resistant monochrome corner mount camera

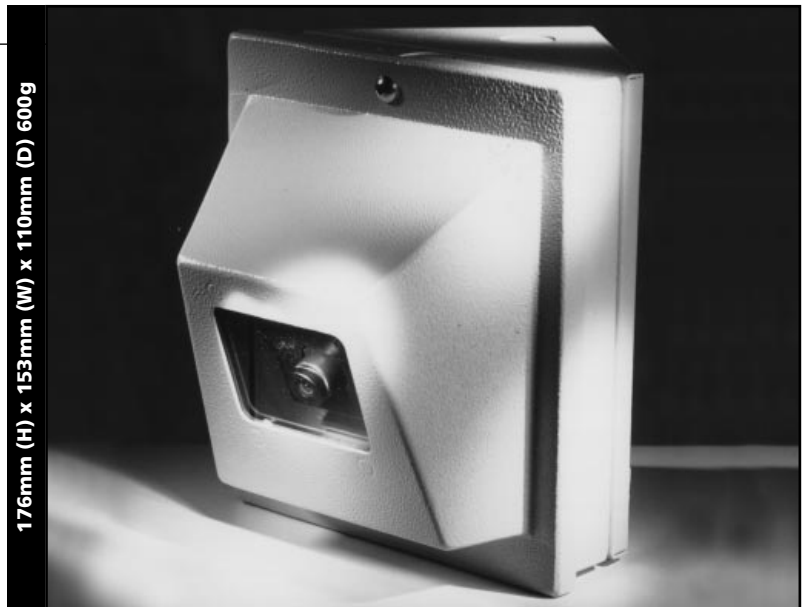
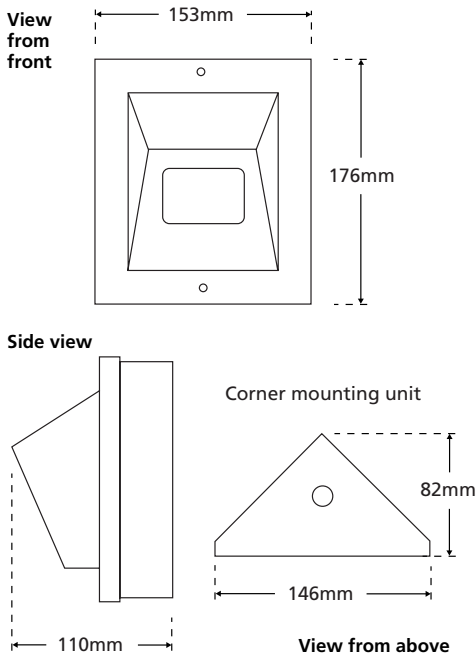

- 1/3" CCD
- 380 TV lines
- 0.3 lux sensitivity
- Supply voltage: 12 Vdc

Lens options	
Lens	Product Code
4.0mm	CM-310VR
2.5mm	CM-310VR/2.5
6.0mm	CM-310VR/6.0
8.0mm	CM-310VR/8.0
12.0mm	CM-310VR/12.0

All lens options are the same price

- Superb picture quality
- Beige, powder-coated, 1.5mm stainless steel housing designed to IP65
- Easily replaceable, toughened, 4mm thick, polycarbonate viewing window
- Smoked viewing window also available - product code: VR-WGR
- Tamper-proof upgrade kit available - product code: VR-TRK
- Camera module mounted on manually adjustable miniature 'swivel and tilt' cradle, for exact camera positioning
- Comes with built-in 220Vac heater and thermostat to prevent misting

*"These units are small, can withstand a very high level of abuse and we would recommend their use"*

PSI Magazine Bench Test - October 1998

See Also:



CM-310VR/AI  
Auto-iris option

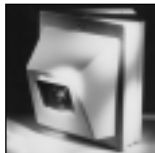

CM-510VR  
High resolution option



SM-610VR  
Outdoor colour surface mount camera

VIDEO	SPECIFICATION	MOD-308 camera module
	Image sensor	1/3" CCD sensor, 512 (H) x 582 (V) pixels
	Horizontal resolution	380 TV lines or greater
	Lens options	SEE TABLE
	Electronic shutter	Automatic linear shutter
	Sensitivity	0.3 lux
	Video output	CCIR, 1Vp-p, 75 Ohms
	Supply voltage	12 Vdc ± 10%
Working temperature	-18°C to +60°C	

Specification and availability of products are subject to change without notice