

Verifier

The Verifier is a user and engineer friendly 8 zone Multiplex expandable control panel in 24 and 64 zone versions, with extensive alarm verification and fault reporting features. It also allows remote upload/download.

• General Features

- Easy to use "menu" driven interface
- 8 on-board zones in 24 and 64 zone versions
- "True" SPLIT, BLOCK and PART GUARD modes
- Remote keypad architecture
- 16 character SUPERTWIST backlit LCD display
- Separate master and installer codes
- Textual zone and user names
- 250/500 event log stored in non-volatile memory
- Single zone monitor with loop resistance display
- "Force Call" feature for simple remote technical support
- Fully compatible with Europlex hardware and software products
- Designed and manufactured to comply with IS 199 1987 & BS 4737

• Hardware Features

- 8 on-board dual EOL monitored zones
- 6 of the above are programmable as inertia sensor inputs
- 4 on-board open collector O/Ps for digital communicator
- 2 on-board fused bell/siren outputs
- Dedicated on-board EOL bell tamper return



• Communications

- Remote/onsite UPLOAD/DOWNLOAD using Panelman II
- Remote/onsite monitoring via Eurodial
- Serial printer port as standard
- Compatible with "Filesaver"
- Networking via "Euronetwork" and "Network XII"
- DM1200 digimodem (16 ch./1200 Baud)

For more details

For more information on this product, please see the Verifier Installation manual.

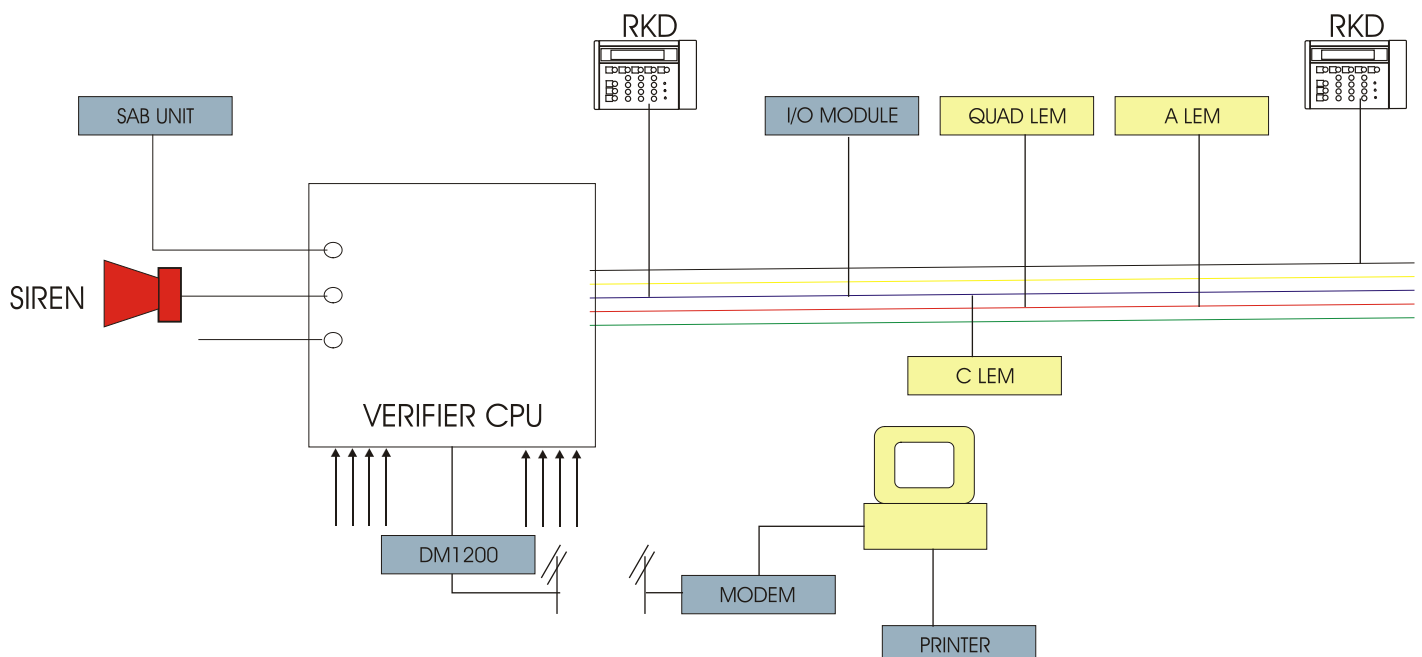

Technical Specifications

Controller	
Cabinet dimensions:	233mm x 357mm x 80mm
Mains supply:	230V AC + 10%, - 15%
Power supply:	Approx. 700mA/1A
Power Consumption:	80mA
Fault indications:	Numerous including fuse, battery, mains fail and restore
On-board outputs:	4 Darlington drivers 2 12V Bell/Siren O/Ps 2 2A Relays
Display:	1 line x 16 char. backlit LCD
Memory backup:	On-board lithium cell
Temperature range:	-10°C to +55°C
Humidity range:	0% to 90%, non-condensing

Remote Keypad Display	
Dimensions:	122mm x 175mm x 23mm
Display:	16 character, backlit SUPERTWIST LCD
Power supply:	+10V DC minimum
Power Consumption:	45mA Quiescent
Keypad:	20 button illuminated keypad

How To Order

Product	Code
Verifier 24 Control Panel	2500-001
Verifier 64 Control Panel	2520-001
Verifier 24 PCB	2501-001
Verifier 64 PCB	2521-001
Verifier RKD Complete	3800
Verifier RKD PCB	3801
Verifier Cabinet	1650

Europlex Technologies (www.europlex.ie)

Europlex Technologies [Ireland] Ltd .

Clonshaugh Industrial Estate, Clonshaugh, Dublin 17, Ireland.

Tel: +353 - 1 - 2500500 Fax: +353 - 1 - 2500590

e-mail: sales@europlex.ie

Europlex Technologies [UK] Ltd.

Ground Floor, Trent House, University Way, Cranfield Technology Park, Bedford, MK43 0AN, England.

Tel: +44 - 1234 - 757100 Fax: +44 - 1234 - 757101

e-mail: sales@europlex-uk.com

Europlex Technologies [USA] Inc .

Suite 106, 1700 Enterprise Way, SE Marietta, GA 30067, USA

Tel: +1 - 770 - 818 - 0456 Fax: + 1 - 770 - 818 - 0239

e-mail: sales@europlex.com

Europlex Technologies [Canada] Inc .

Unit 6, 70 Dynamic Drive, Scarborough, Ontario, M1V 2N2, Canada.

Tel: +1 - 416 - 7544313 Fax: +1 - 416 - 7548992

e-mail: eplexcan@europlex.ie