

DC Controlled Lenses

G0216NDDC

- Suitable for 1/2" and 1/3" Colour and B&W Cameras
- CS Mount
- High Standard of Optical and Mechanical Quality
- Without Built-in Auto Iris Amplifier
- With 4-pin connector
- Adjustable Slip-ring Mount for Cable Positioning



Specifications:

Focal length (f)	2.6 mm
Aperture range (F)	F1.6-F360
Mount	CS
Nominal format size	1/2"
Flange focal length	12.5 mm
Horizontal angle of view at nominal format size	116.5°
Minimum object distance (M.O.D.)	0.1 m
Screw-in depth	5.0 mm
Filter screw size	-
Cable length	Approx. 25 cm
Slip-ring mount	340°-360° Variable adjustment range
Iris control system	Galvanometer
4-pin plug	Standard
Temperature range	-20°C to +50°C
Dimensions (LxDxH)	33x34.5x23 mm
Weight	40 g

Accessories	
EDP No. / Type	Description
43094 ACB	Auto iris control box for DC iris lenses to AI output. With integrated Level and ALC adj. potentiom.

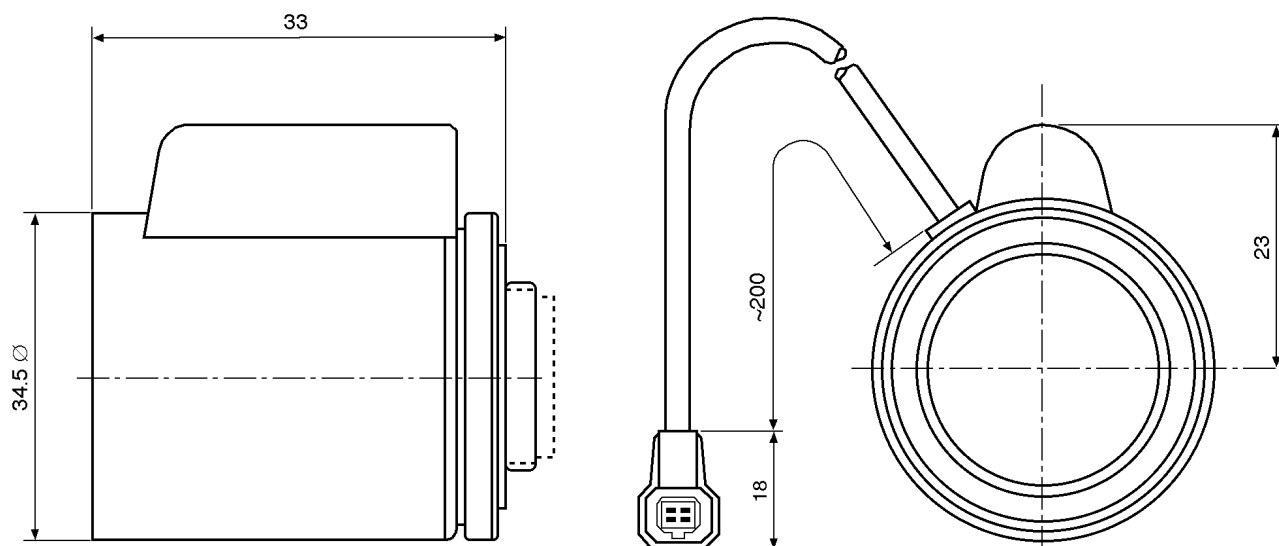

Maße/Dimensions: mm

e-mail: info@eneo-security.com • www.eneo-security.com