

DH-PFB603C

Ceiling Mount Bracket



- Aluminum alloy material, cost-effective
- Dedicated for particular cameras, beautiful and elegant designed



Series overview

Ideal for mounting cameras, it works in temperatures ranging from -40°C to $+60^{\circ}\text{C}$ (-40°F to $+140^{\circ}\text{F}$) and in environments with relative humidity of less than 90%.

Technical Specification

Structure

Material	Aluminum alloy
Dimensions	246.0 mm × 88.0 mm × 493.0 mm (9.68" × 3.46" × 19.41") (L × W × H)
Color	White
Net Weight	0.67 kg (1.48 lb)
Gross Weight	0.88 kg (1.94 lb)
Load Bearing	3.0 kg (6.61 lb)
Installation	Ceiling mount
Rotation Angle	Pan: 0° to 180° ; Tilt: -30° to 30°
Applicable Camera	Please see "Accessory Selection"
Product Dimensions	215.0 mm × 95.0 mm × 520.0 mm (8.46" × 3.74" × 20.47") (L × W × H)
Packaging Dimensions	450.0 mm × 490.0 mm × 520.0 mm (17.71" × 19.29" × 20.47") (L × W × H)
Packaging Method	10 pcs in each master carton

Environment

Operating Temperature	-40°C to $+60^{\circ}\text{C}$ (-40°F to $+140^{\circ}\text{F}$)
Operating Humidity	< 90% (RH)
Storage Temperature	-40°C to $+60^{\circ}\text{C}$ (-40°F to $+140^{\circ}\text{F}$)
Storage Humidity	10%–90% (RH)

Ordering Information

Type	Model	Description
Camera Mount	DH-PFB603C	Ceiling Mount Bracket

Installation

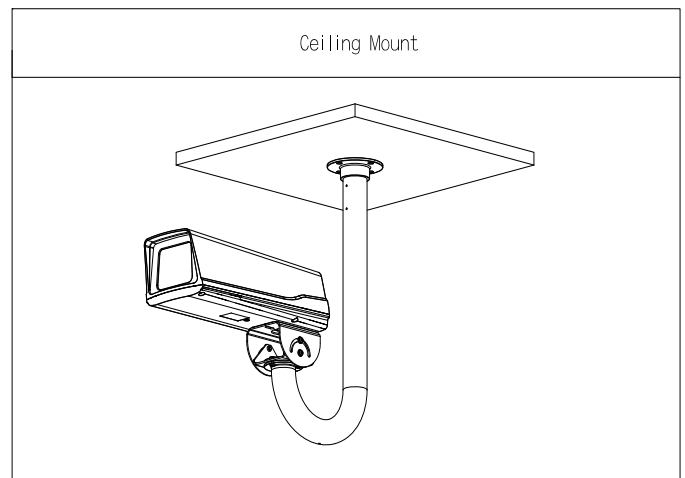

Dimensions (mm[inch])

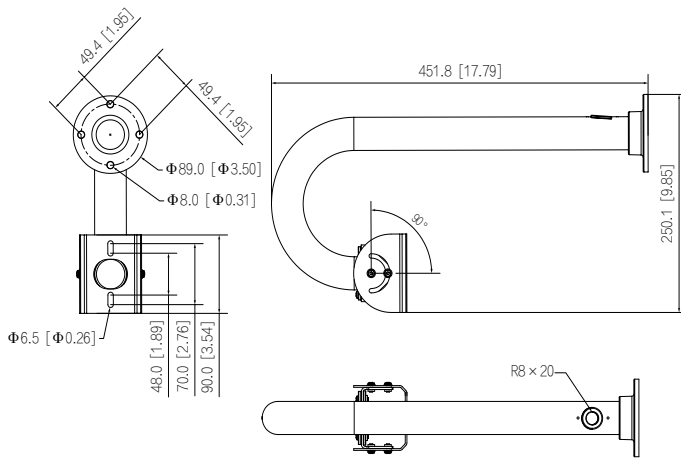

Package Information

- Ceiling Mount Bracket *1
- M6 Metal Expansion Bolt *4
- 1/4-20x8 UNC screws *2
- M6x10 screws *2
- S3.0 wrench *1