

# Hybrid Network PTZ Camera

400 x 300 Thermal Sensor and a 2MP CMOS Sensor



## System Overview

The Hybrid Thermal Network PTZ camera combines an uncooled VOx 400 x 300 thermal imager with a 2 MP visible-light sensor for cost-effective, long-range surveillance in a rugged all-in-one package. The thermal imager coupled with an athermalized, focus-free lens produces crisp images in total darkness and sees through rain, fog, and snow. The visible imager with a 30x zoom lens and IR illuminators delivers superior video in any lighting condition. The built-in Fire Detection feature identifies a rapid temperature rise and warns of a potential fire. Hybrid thermal cameras let you see the visible and the invisible. .

## Functions

### Uncooled Vanadium Oxide (VOx) Technology

Dahua thermal cameras use an uncooled Vanadium Oxide (VOx) sensor that delivers higher thermal sensitivity in a more compact and cost-effective package. Vanadium Oxide cameras are also more reliable, as compared to other thermal imaging technologies, due to less moving parts.

### Athermalized Lens

The athermalized lens used in Dahua thermal cameras maintains the focus position passively and without power over a wide temperature range.

### High Thermal Sensitivity

The VOx detector offers high thermal sensitivity (< 40 mK) that allows Dahua thermal cameras to distinguish objects in a scene with minimal temperature differences. The camera captures detailed images where thermal contrast between object and background is minimal.

### Thermal Color Palettes

Dahua thermal cameras provide a choice of color palettes onboard the camera that help to distinguish thermal variations and patterns in an image. The color tones correspond to the apparent surface temperatures of the target.

### Thermal Camera

- 400 x 300 VOx Uncooled Thermal Sensor Technology
- Athermalized Lens, Focus-free
- 25 mm or 50 mm Fixed Thermal Lens Options
- < 40 mK Thermal Sensitivity

### Visible-light Camera

- 1/1.9-in. 2MP Progressive-scan CMOS Sensor
- Powerful 30x Optical Zoom
- Starlight+ Technology

### System Features

- Intelligent Video System with Fire Detection and Alarm Functionality
- Designed for Extreme Temperature Environments
- IP66 Ingress Protection
- Five-year Warranty\*



### Fire Detection and Alarm

With built-in fire detection functionality, the camera can detect a rapid rise in temperature over a short time and issue an alarm for a potential fire event even at long distances. Because thermal cameras are sensitive to temperature, they provide higher fire detection accuracy than standard cameras, making them particularly fit for applications such as forest fire prevention.

### Starlight+ Technology

For challenging low-light applications, Dahua's Starlight Technology offers best-in-class light sensitivity, capturing details in low light applications. The visible light camera uses a set of optical features to balance light throughout the scene, resulting in clear images in dark environments.

### Intelligent Video System (IVS)

IVS is a built-in video analytic algorithm that delivers intelligent functions to monitor a scene for Tripwire violations, intrusion detection, and abandoned or missing objects. A camera with IVS quickly and accurately responds to monitoring events in a specific area.

### Interoperability

The camera conforms to the ONVIF (Open Network Video Interface Forum) and to the PSIA (Physical Security Interoperability Alliance) specifications, ensuring interoperability between network video products regardless of manufacturer.

### Environmental

With a temperature range of -40 °C to +70 °C (-40 °F to +158 °F), the camera is designed for extreme temperature environments. The camera complies with the IP66 rating makes it suitable for demanding outdoor applications.

### Protection

The camera allows for ±15% input voltage tolerance, suitable for the most unstable conditions for outdoor applications. Its 6 KV lightning rating provides effective protection for both the camera and its structure against lightning

## Technical Specification

### Thermal Camera

Image Sensor	Uncooled VOx Microbolometer
Effective Pixels	400 (H) x 300 (V)
Pixel Size	17 $\mu$ m
Thermal Sensitivity (NETD)	< 40 mK at f/1.0
Spectral Range	7 $\mu$ m to 14 $\mu$ m
Image Setting	Brightness, Sharpness, ROI, AGC, FFC, 3D DNR
Color Palettes	14, including: Whitehot, Blackhot, Ironrow, Icefire, Fusion, Rainbow, Globow, Iconbow1, Iconbow2

### Thermal Lens

Lens Type	Fixed		
Focus Control	Athermalized, Focus-free		
Focal Length	25 mm	50 mm	
Angle of View	H: 15.5° V: 11.6°	H: 7.7° V: 5.8°	
Effective Distance, human (1.80 m x 0.50 m) <sup>1</sup>	Detection	1000 m (3281 ft)	1700 m (5577 ft)
	Recognition	250 m (820 ft)	430 m (1411 ft)
	Identification	125 m (410 ft)	220 m (722 ft)
Effective Distance, vehicle (2.30 m x 2.30 m) <sup>1</sup>	Detection	3000 m (9843 ft)	5000 m (16404 ft)
	Recognition	720 m (2362 ft)	1400 m (4593 ft)
	Identification	360 m (1181 ft)	700 m (2297 ft)

### Visible-light Camera

Image Sensor	1/1.9-in. Progressive-scan CMOS
Effective Pixels	1944 (H) x 1092 (V)
Electronic Shutter Speed	1/1 s to 1/30,000 s
Minimum Illumination	Color: 0.001 lux at F1.5 B/W: 0.0001 lux at F1.5 0 lux with IR On
S/N Ratio	More than 55 dB
IR Distance	150.0 m (492.17 ft)
IR On/Off Control	Auto, Manual
IR LEDs	Four (4)

### Visible-light Lens

Focal Length	6 mm to 180 mm
Maximum Aperture	F1.5 to F4.3
Angle of View	Horizontal: 59° to 2.4°
Optical Zoom	30x
Focus Control	Auto, Manual
Close Focus Distance	100 mm to 1000 mm (0.33 ft to 3.28 ft)

### Pan/Tilt

Range	Pan: 0° to 360° endless Tilt: -10° to 90°
Manual Control Speed	Pan: 0.1° to 200° /s Tilt: 0.1° to 120° /s
Preset Speed	Pan: 0.1° to 240° /s Tilt: 0.1° to 200° /s
Presets	300
PTZ Mode	5 Pattern, 8 Tour, Auto Pan, Auto Scan
Speed Setup	Human-oriented Focal Length, Speed Adaptation
Power Up Action	Auto restore to previous PTZ and lens status after power failure
Idle Motion	Activate Preset, Scan, Tour, or Pattern if there is no command in the specified period
Protocol	DH-SD, Pelco-P/D (auto recognition)

### Video

Compression	H.264, MJPEG
Frame Rate	Main Stream: Thermal: 1280 x 1024 (default) or 720p at 30 fps Visible: 1080p (default) or 720p at 30 fps
	Sub Stream: Thermal: 640 x 512 (default) or 320 x 256 at 30 fps Visible: CIF (default) or D1 at 30 fps
Bit Rate Control	CBR, VBR
Bit Rate	H.264: 640 to 8192 Kbps
Day/Night	Auto (ICR), Color, B/W
BLC Mode	BLC, HLC, WDR
White Balance	Auto, ATW, Indoor, Outdoor, Manual
Noise Reduction	3D DNR
Motion Detection	Off, On (4 zones, Rectangle)
Region of Interest	Off, On (4 zones)
Defog	On, Off
Digital Zoom	19x
Flip	180°
Mirror	Off, On
Privacy Masking	Off, On (4 areas, Rectangle)

### Network

Ethernet	RJ-45 (10/100 Base-T)
Protocol	IPv4/IPv6, HTTP, HTTPS, 802.1x, Qos, FTP, SMTP, UPnP, SNMP, DNS, DDNS, NTP, RTSP, RTP, TCP, UDP, IGMP, ICMP, DHCP, PPPoE, ONVIF
Interoperability	ONVIF Profile S & G, PSIA, CGI
Streaming Method	Unicast, Multicast
Maximum User Access	10 Users, 20 Users
Edge Storage	Network Attached Storage (NAS) Local PC for Instant Recording Micro SD Card Slot, maximum 256 GB Memory Status Display: Normal, Error, Active, Formatting, Lock
Web Viewer	IE 11, Chrome, Firefox
Management Software	SmartPSS, DSS
Mobile Operating System	Android, IOS

### Audio

Compression	G.711a, G.711Mu, AAC
-------------	----------------------

1. The Detection, Recognition, and Identification values shown are nominal values and should be used as estimates only. Exact value calculations depend on a wide variety of conditions.

Certifications

Electromagnetic Compatibility (EMC)	FCC CFR 47 Part 15 Subpart B
-------------------------------------	------------------------------

Interface

Video	1.0 Vp-p, 75 Ω (use for camera installation)
Audio	Input: One (1) Channel, RCA Output: One (1) Channel, RCA
RS485	One (1) Port
Alarm	Input: Seven (7) Channels Output: Two (2) Channel

Electrical

Power Supply	24 VAC, 3 A (±15%)
Power Consumption	Maximum 17 W, 38 W (with Heater and IR on)

Environmental

Operating Condition	-40° C to +70° C (-40° F to +158° F) Less than 95% RH Initiate start up above -40° C (-40° F)
Storage Conditions	-40° C to +70° C (-40° F to +158° F) Less than 95% RH
Ingress Protection	IP66

Construction

Casing	Metal
Dimensions	ø239.70 mm x 382.0 mm (ø9.44 in. x 15.04 in.)
Net Weight	6.80 kg (14.99 lb)
Gross Weight	9.50 kg (20.94 lb)

Intelligence

IVS triggers an alarm and takes a defined action for the following events:

Standard Features	<ul style="list-style-type: none"> <li>Tampering with the camera.</li> <li>Camera loses or changes focus drastically.</li> <li>Error writing to an onboard Micro SD card.</li> <li>Error sending or receiving data over the network.</li> <li>Unauthorized access to the camera.</li> </ul>
Premium Features	
Tripwire	A target crosses a user-defined line.
Intrusion	A target enters or exits a defined perimeter.
Abandoned/Missing Object	A target leaves an object in designated area, or a target removes an object from the same designated area.
Advanced Features	
Fire Detection	Detects a rapid rise in temperature over a short time and issues an alarm for a potential fire.

Ordering Information

Type	Part Number	Description
Hybrid Network Camera	DH-TPC-SD8420N-B25Z30	Hybrid Network PTZ Camera, Thermal: 400 x 300, 25 mm lens, Visible-light: 2 MP 30x, IVS
	DH-TPC-SD8420N-B50Z30	Hybrid Network PTZ Camera, Thermal: 400 x 300, 50 mm lens, Visible-light: 2 MP 30x, IVS
Accessories, included	PFA111	Mount Adapter
	PFB303W	Wall Mount
	AC24V/3A	24 VAC, 3 A Power Adapter
Accessories, optional	PFA120	Junction Box
	PFA140	Waterproof Power Box
	PFA150	Pole Mount
	PFA151	Corner Mount
	PFB300C	Ceiling Mount
	PFB303S	Parapet Mount

Accessories

Included:



PFA111  
Mount Adapter



PFB303W  
Wall Mount



AC24V/3A  
Power Adapter

Optional:



PFA120  
Junction Box



PFA140  
Waterproof Power Box



PFA150  
Pole Mount





PFA151  
Corner Mount



PFB300C  
Ceiling Mount

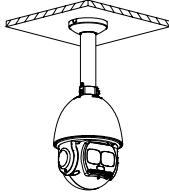
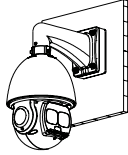
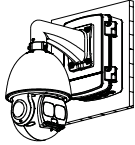

PFB303S  
Parapet Mount

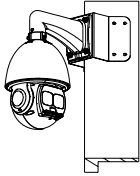
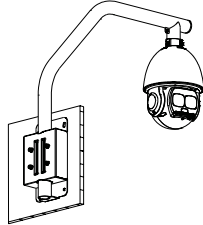
<b>Ceiling Mount</b>	<b>Junction Mount</b>
PFA111 + PFB300C	PFA111 + PFB303W + PFA120
	
<b>Power Box Mount</b>	<b>Pole Mount</b>
PFA111 + PFB303W + PFA140	PFA111 + PFB303W + PFA150
	
<b>Corner Mount</b>	<b>Parapet Mount</b>
PFA111 + PFB303W + PFA151	PFA111+ PFB303S
	

**Dimensions(mm/in.)**

