

DH-IPC-HFW5100-IRA

1.3Megapixel HD Network Water-proof IR-Bullet Camera



Features

- 1/3" 1.3Megapixel progressive scan Aptina CMOS
- H.264 & MJPEG dual-stream encoding
- 25/30fps@1.3M(1280×960)& 25/30fps@720P(1280×720)
- DWDR, Day/Night(ICR), 3DNR,AWB,AGC,BLC
- Multiple network monitoring: Web viewer, CMS(DSS/PSS) & DMSS
- 3.3mm~12mm varifocal lens (7mm~22mm optional)
- Max. IR LEDs Length 100m
- IP66, PoE

DH-IPC-HFW5100-IRA

Technical Specifications

Model	DH-IPC-HFW5100-IRA		
Camera			
Image Sensor	1/3" 1.3Megapixel progressive scan CMOS		
Effective Pixels	1280(H)x960(V)		
Scanning System	Progressive		
Electronic Shutter Speed	Auto/Manual, 1/3(4)~1/10000s		
Min. Illumination	0.05Lux/F1.2 (Color), 0.005Lux/F1.2(B/W);0Lux/F1.2(IR on)		
S/N Ratio	More than 50dB		
Video Output	1 channel BNC (1.0Vp-p, 75Ω)		
Camera Features			
Max. IR LEDs Length	100m		
Day/Night	Auto(ICR)/Color/B/W		
Backlight Compensation	BLC / HLC / DWDR		
White Balance	Auto/Manual		
Gain Control	Auto/Manual		
Noise Reduction	3D		
Privacy Masking	Up to 4 areas		
Lens			
Focal Length	3.3~12mm (7~22mm optional)		
Max Aperture	F1.4		
Focus Control	Manual		
Angle of View	H: 72.5° ~25.8° (35.12° ~13.42° optional)		
Lens Type	Manual/Auto Iris(DC)		
Mount Type	Board-in Type		
Video			
Compression	H.264/ H.264H/ MJPEG		
Resolution	1.3M(1280×960)/720P(1280×720)/D1(704×576/704×480)/CIF(352×288/352×240)		
Frame Rate	Main Stream	1.3M/720P(1 ~ 25/30fps)	
	Sub Stream	D1/CIF(1 ~ 25/30fps)	
Bit Rate	H.264: 32K ~ 8192Kbps		
Audio			
Compression	G.711a/ G.711u/ PCM		
Interface	1/1 channel In/Out		
Network			
Ethernet	RJ-45 (10/100Base-T)		
Wi-Fi	N/A		
Protocol	IPv4/IPv6, HTTP, HTTPS, SSL, TCP/IP, UDP, UPnP, ICMP, IGMP, SNMP, RTSP, RTP, SMTP, NTP, DHCP, DNS, PPPOE, DDNS, FTP, IP Filter, QoS, Bonjour, GB28181		
ONVIF	ONVIF Profile S		
Max. User Access	20 users		

DH-IPC-HFW5100-IRA

Smart Phone	iPhone, iPad, Android, Windows Phone
Auxiliary Interface	
Memory Slot	Micro SD, Max 64GB
RS485	N/A
Alarm	2/1 channel In/Out
PIR Sensor Range	N/A
General	
Power Supply	DC12V, PoE (802.3af)
Power Consumption	<16W
Working Environment	-20°C~+60°C, Less than 95% RH
Ingress Protection	IP66
Vandal Resistance	N/A
Dimensions	288mm×118mm×101mm
Weight	2.5kg

DH-IPC-HFW5100-IRA

Dimensions (mm)

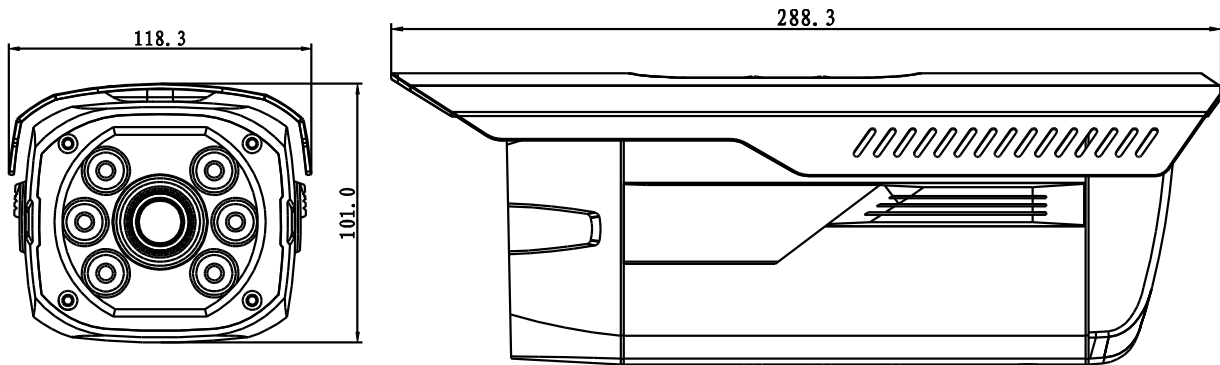

Accessory (optional)



APT80006

Dahua Technology Co., Ltd.

1187BinAn Road, Binjiang District, Hangzhou, China

Tel: +86-571-87688883

Fax: +86-571-87688815

Email: overseas@dahuatech.com

www.dahuatech.com

*Design and specifications are subject to change without notice.

© 2013Dahua Technology Co., Ltd.