



IPS, 30mm TE Cam Cylinder

Part number: CL-IPS02

The CyberLock IPS, 30mm cylinder is a custom modification to a standard cam lock. It is currently used to secure the electronics access door on a pay telephone.

The outer shell is made of nickel-plated brass. The core's electronics are encased in a nickel-plated steel shell. The body threads are 19mm in diameter and have 1mm pitch. The cylinder tendon is 8mm in diameter and has an .8mm pitch. Both the body and the tendon threads are double-D style.

The IPS 30mm has one home position at 0° where the key can be inserted or removed. It rotates a full 360° as shipped. The addition of a stop cam and/or drive cam can control key and latch motions. Please see the standard cam lock data sheet for an example.

Videx does not supply a mounting nut, latch nut, cam latch, or stop cam for this CyberLock.

CyberLock cylinders have several advantages over traditional cylinders:

- Keys cannot be duplicated.
- The lock has no keyway to pick.
- Various entry times and restrictions can be set.
- Both the locks and keys track all actions.

Custom cylinders require a minimum order and additional manufacturing lead-time. Please contact our sales department for details.

IPS, 30mm TE Cam Cylinder

Part number: CL-IPS02

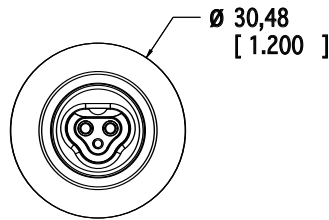
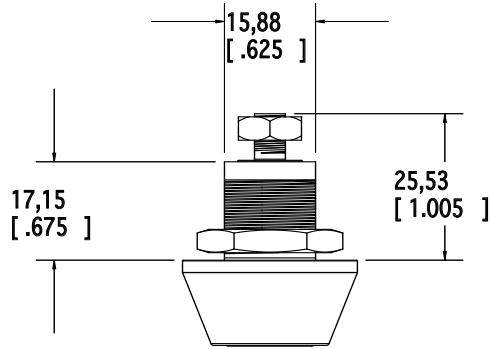

Notes:

Dimensions in mm (inches)
 Drawing not to scale
 Ø indicates diameter

Body and Tendon Style: Double-D, threaded
 Body Diameter: 19mm
 Body Thread Pitch: 1.00mm
 Tendon Diameter: 8mm
 Tendon Thread Pitch: .8mm

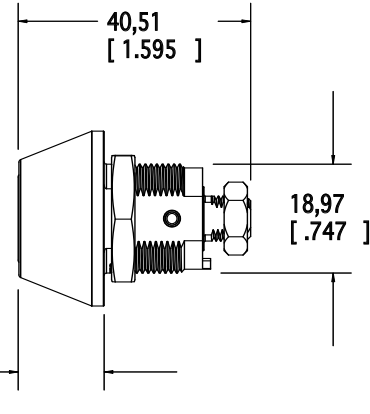

Specifications

- | | |
|-------------------------------------|---|
| Finish | <ul style="list-style-type: none"> • Nickel plating |
| Operating Temperature | <ul style="list-style-type: none"> • -40° to 160° F; -40° to 70° C, non-condensing |
| Power Requirements | <ul style="list-style-type: none"> • None; power is supplied by the key's battery. |
| Hardware Security Features | <ul style="list-style-type: none"> • No keyway to pick. • If torque is applied to the front of the cylinder, it separates from the back half leaving the cylinder in the locked position. • Resists electric charge applied to the face of the lock. |
| Hardware Options | <ul style="list-style-type: none"> • Tamper pin which blocks the locking pin automatically when impact force is applied to the front of the lock. • Hardened metal. |
| Number of Keys per Lock | <ul style="list-style-type: none"> • No limit to the number of keys that the lock can support. |
| Number of Locks per Key | <ul style="list-style-type: none"> • Up to 3300 locks can be accessed with a standard user key. • A Master key has no limit to the number of locks it can access. • A database has no limit to the number of locks or keys it can manage. |
| Lost Keys | <ul style="list-style-type: none"> • The system can designate and disable lost keys. |
| Access Schedules | <ul style="list-style-type: none"> • Schedules programmed into the CyberKey provide complete control over specific days and times that a key will operate. A key can use up to 49 different schedules to access locks. • A database has no limit to the number of schedules it can manage. • Holidays may be set as exceptions to the schedules. |
| Audit Capacities | <ul style="list-style-type: none"> • The lock remembers the last 1100 events with date and time. • A key remembers up to 3900 events with date and time. It can be set to keep only the most recent set of events or to stop operating when its audit trail is full. |
| Electronic Security Features | <ul style="list-style-type: none"> • Key Expiration – a begin/end date range can be set during which the key will work. • Delayed entry – a lock can be set to delay entry for up to 20 minutes. • Multiple key custody – a lock may be set to require more than 1 key (up to 4) before opening. |
| Electronic Rekeying | <ul style="list-style-type: none"> • Rekeying a system is done via the software; no need to install new locks and issue new keys. |