

**BOSCH**

Invented for life

# LTC 0630 Series Dinion2X Day/Night Camera



- ▶ **Advanced Image Processing Technology**
- ▶ **Improved XF-Dynamic engine with SmartBLC**
- ▶ **Detail enhancement**
- ▶ **True Day/Night performance with switchable filter**
- ▶ **1/2-inch CCD sensor**

The LTC 0630 Dinion2X Day/Night camera is a high-performance, surveillance camera. It uses a 1/2-inch CCD sensor and incorporates advanced digital signal processing for outstanding picture performance.

The advanced image processing enhances sensitivity; the improved XF-Dynamic engine extends the dynamic range. This unique combination provides a sharper, more detailed image with outstanding accuracy in color reproduction even under harsh lighting conditions.

The Dinion2X camera is easy to install and ready to use, and offers the best solution for demanding scene conditions. The day/night feature ensures the highest image quality possible at any time. Depending on the available light the camera will automatically switch from color to monochrome.

All Dinion cameras are supplied ready to operate. Simply attach the lens, connect video and then power. Six distinct pre-programmed operational modes are stored in the camera. Recall the mode that suits your application for optimized performance.

The camera automatically detects the lens type. The lens wizard ensures accurate back-focusing for perfectly sharp pictures at all times. For especially challenging situations where fine tuning or special settings are required, the camera parameters can be individually set using the control buttons on the side of the camera and an On-screen Display (OSD).

## Functions

### XF-Dynamic and Image Processing

Improved XF-Dynamic technology and highly accurate digital signal processing optimally captures the detail in both bright highlights and deep shadows simultaneously. The Dinion2X maximizes the information visible in the picture even with strong backlighting.

### SmartBLC

Turn on SmartBLC to automatically compensate the image without the need for complicated set-up.

### Detail Enhancement

Features such as Autoblack and Sharpness further improve the details in a scene, pixel by pixel.

### Day/Night Mode

The day/night mode provides enhanced night viewing by increasing the IR sensitivity. The IR filter can switch from color to monochrome automatically by either sensing the illumination level or via the alarm input. The filter can be switched manually via the alarm input, through the camera menu or via the Bilinx coaxial control interface. An internal through-the-lens IR detector enhances the monochrome mode stability, as it prevents reverting to the color mode when IR illumination is dominant. IR contrast is also measured and used to handle reflected IR light in outdoor scenes.

**Privacy masking**

Four different privacy zones allow specific parts of a scene to be blocked. Pre-program any part of the scene to be masked.

**Default Shutter**

The default shutter speed captures fast moving objects when sufficient light is available. When light levels fall and other adjustments have been exhausted, the shutter speed reverts to a standard setting to maintain sensitivity.

**Bilinx Technology**

Bilinx is a bidirectional communication capability embedded in the video signal of all Bosch Dinion cameras. Technicians can check status, change camera settings and even update firmware from virtually anywhere along the video cable. Bilinx reduces service and installation time, provides for more accurate set-up and adjustment, and improves overall performance. In addition, Bilinx uses the standard video cable to transmit alarm and status messages, providing superior performance without additional installation steps.

**Lens Wizard**

The Lens Wizard automatically detects the lens type and helps focus the lens at the maximum opening to ensure proper focus is maintained throughout the 24-hour cycle. No special tools or filters are required.

**Ease of installation**

Several features are available that make installation easy:

- Power and alarm connections have cable connectors which can be removed even when the camera is mounted.
- A built-in test pattern generator produces signals to test and fault-find cables.
- A multi-language On-Screen Display (OSD) increases user compatibility.

**Programmable Modes**

Six independent, pre-programmed operating modes support typical applications, but are fully programmable for individual situations. Switching between modes is easy via Bilinx or the external alarm input.

**High efficiency**

A high efficiency power supply improves maximum operating temperature.

**Video Motion Detection**

The built-in video motion detector allows you to select a programmable area with individual thresholds. The global scene change detector minimizes false alarms caused by sudden lighting condition changes, such as switching on or off the indoor or security lighting. When motion is detected, alarms can be displayed in the video signal, the output relay can be closed or an alarm message can be transmitted via Bilinx.

**SensUp Dynamic**

By increasing the integration time up to 10 times on the CCD, the effective sensitivity is dramatically enhanced. This is especially useful when relying only on moonlight for illumination.

**Typical applications:**

- Outdoor perimeters
  - low light
  - IR light
- Traffic monitoring
  - highway
  - traffic intersections
  - emergency response coordination
- Tunnels
- Car parks (outdoor)
- Restricted access locations such as:
  - prisons
  - ports / freight terminals
  - military facilities
  - border control and homeland security
- Casino and gambling centers.

**Certifications and Approvals**

Region	Certification
Europe	CE Declaration of Conformity
USA	UL FCC
Canada	CSA

**Electro Magnetic Compatibility**

Emission	EN55022 class B, FCC part 15 class B, EN6100-3, EN50121-4
Immunity	EN50130-4 (CE), EN50121-4 (CE)
Vibration	Camera with 500 g (1.1 lbs) lens according to IEC60068-2-6

**Safety**

LTC0630/11: UL1950-1, CSA 22.2 No. 950-1, EN60950-1 (CE), UL60950, CAN/CSA No. 60950

LTC0630/51: UL1950-1, CSA 22.2 No. 950-1, EN60950-1 (CE), EN61000-3-2 2000 +A2:2005, EN61000-3-3 1995 +A1:2001 +A2:2005

LTC0630/21 and LTC0630/61: UL1950-1, CSA 22.2 No. 950-1, EN60950-1 (CE), UL60950, CAN/CSA No. 60950

## Installation/Configuration Notes

### Dimensions

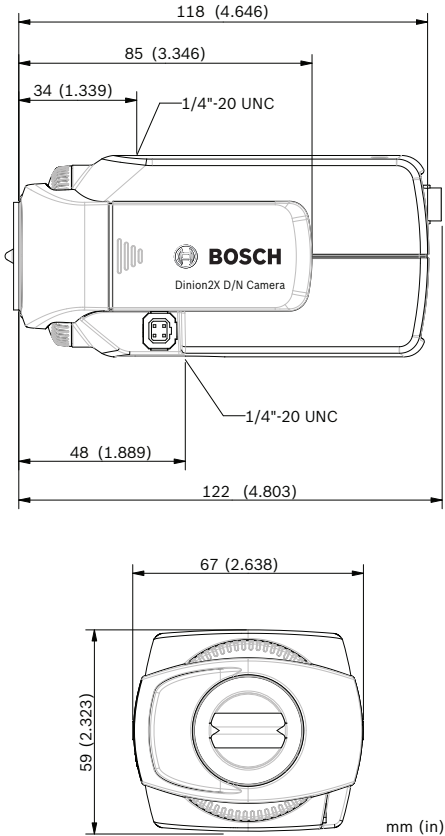

### Parts Included

Quantity	Component
1	LTC 0630 Series Dinion2X Day/Night Camera
1	C/CS – mount conversion ring
1	Spare male 4 – pin lens connector
	Lens not included

### Technical Specifications

#### Electrical

Model No.	Rated Voltage	Rated Frequency
LTC 0630/11	24 VAC ±10%	50 Hz
	12 VDC ±10%	
LTC 0630/21	24 VAC ±10%	60 Hz
	12 VDC ±10%	
LTC 0630/51	230 VAC ±10%	50 Hz
LTC 0630/61	120 VAC ±10%	60 Hz

Power Consumption	350 mA (12 VDC) 250 mA (24 VAC) 70 mA (120-240 VAC)
-------------------	---

CCD Type	1/2-inch interline
----------	--------------------

#### Active Pixels

PAL Model:	752 x 582
NTSC Model	768 x 494

#### Sensitivity (3200 K, scene reflectivity 89%, F1.2)

	Full video (100 IRE)	Usable picture (50 IRE)	Usable picture (30 IRE)
Color	1.40 lx (0.13 fc)	0.31 lx (0.029 fc)	0.0991 lx (0.0097 fc)
Color + SensUp 10x	0.14 lx (0.013 fc)	0.031 lx (0.0029 fc)	0.00991 lx (0.0009 fc)
Monochrome	0.57 lx (0.053 fc)	0.121 lx (0.0112 fc)	0.0391 lx (0.0036 fc)
Monochrome + SensUp 10x	0.057 lx (0.0053 fc)	0.0121 lx (0.00112 fc)	0.00391 lx (0.00036 fc)

Horizontal Resolution	540 TVL
-----------------------	---------

Signal-to-Noise Ratio	>50 dB
-----------------------	--------

Video Output	Composite video 1 Vpp, 75 ohm
--------------	-------------------------------

Synchronization	Internal, Line Lock, HV-lock and Genlock (Burst lock) selectable
-----------------	--

Shutter	Auto (1/50 [1/60] to 1/10000) selectable Auto (1/50 [1/60] to 1/50000) automatic flickerless, fixed selectable
---------	--

Sensitivity up	Adjustable from Off up to 10x
----------------	-------------------------------

Day/Night	Color, Mono, Auto
-----------	-------------------

Auto Black	Automatic continuous, Off
------------	---------------------------

Dynamic engine	XF-Dynamic, SmartBLC
----------------	----------------------

Dynamic range	96 dB (16-bit image processing)
---------------	---------------------------------

Dynamic Noise Reduction	Auto, On/off selectable
-------------------------	-------------------------

Sharpness	Sharpness enhancement level selectable
-----------	--

SmartBLC	On/Off
----------	--------

AGC	AGC On or Off (0 – 30 dB) selectable
-----	--------------------------------------

Peak White Invert	On/Off
-------------------	--------

White Balance	ATW, ATWhold and manual (2500 to 10000K)
---------------	--

Alarm Output	VMD or Bilinx
--------------	---------------

Alarm Input (TTL)	Profile switching, +3.3 V nominal, +40 VDC max.
-------------------	---

Alarm Output Relay	30 VAC or +40 VDC, Max 0.5 A continuous, 10 VA
--------------------	--

External Synchronization Input	75 ohm or high impedance selectable
--------------------------------	-------------------------------------

Cable Compensation	Up to 1000 m (3000 ft) coax without external amplifiers (automatic set-up in combination with Bilinx coaxial communication)
--------------------	---

Camera ID	17 character editable string, position selectable
-----------	---

Test Pattern Generator	Color bars 100%, Greyscale 11-step, Sawtooth 2H, Checker board, Cross hatch, UV plane
Lens Types	Manual, DC- and Video-Iris auto-detect with override DC-iris drive: max. 50 mA continuous Video-iris: 11.5 VDC ±0.5, max. 50 mA continuous
Lens Mount	CS (max lens protrusion 5 mm, 0.2 inch), C-mount compatible with supplied adapter ring
Modes	6 preset programmable modes
Remote Control	Bilinx coaxial bi-directional communication
Video Motion Detection	One area, fully programmable
Privacy Masking	Four independent areas, fully programmable
Controls	OSD with soft-key operation (multi-lingual)

**Mechanical**

Dimensions (H x W x L)	58 x 66 x 122 mm (2.28 x 2.6 x 4.8 inch) without lens
Weight	450 g (0.99 lbs) without lens
Color	RAL 9007 Metallic Titanium
Tripod Mount	Bottom (isolated) and top 1/4-inch 20 UNC

**Environmental**

Operating Temperature	-20°C to +55°C (-4°F to 131°F)
Storage Temperature	-40°C to +70°C (-40°F to +158°F)
Operating Humidity	20% to 93% RH
Storage Humidity	up to 98% RH

**Ordering Information**

<b>LTC 0630/11 Dinion 2X Day/Night Camera</b> 1/2-inch, 540 TVL, PAL, 2X DSP, 24 VAC/12 VDC, 50 Hz	<b>LTC 0630/11</b>
<b>LTC 0630/21 Dinion 2X Day/Night Camera</b> 1/2-inch, 540 TVL, NTSC, 2X DSP, 24 VAC/12 VDC, 60 Hz	<b>LTC 0630/21</b>
<b>LTC 0630/51 Dinion 2X Day/Night Camera</b> 1/2-inch, 540 TVL, PAL, 2X DSP, 230 VAC, 50 Hz	<b>LTC 0630/51</b>
<b>LTC 0630/61 Dinion 2X Day/Night Camera</b> 1/2-inch, 540 TVL, NTSC, 2X DSP, 120 VAC, 60 Hz	<b>LTC 0630/61</b>

**Ordering Information**

**Accessories**

<b>EX12LED8M LED Infrared Illuminator</b> Infrared w/ 42 LEDs, 850 nm, Med Beam 30°, 12/24 VRB, 0.5 amp, Photocell	<b>EX12LED8M</b>
<b>EX12LED9M LED Infrared Illuminator</b> Infrared w/ 42 LEDs, 940 nm, Med Beam 30°, 12/24 VRB, 0.5 amp, Photocell	<b>EX12LED9M</b>
<b>EX12LED8W LED Infrared Illuminator</b> Infrared w/ 42 LEDs, 850 nm, Wide Beam 60°, 12/24 VRB, 0.5 amp, Photocell	<b>EX12LED8W</b>
<b>EX12LED9W LED Infrared Illuminator</b> Infrared w/ 42 LEDs, 940 nm, Wide Beam 60°, 12/24 VRB, 0.5 amp, Photocell	<b>EX12LED9W</b>
<b>EX12LED-3BD-8M Infrared Illuminator</b> EX12LED IR Illuminator, 850 nm, 30 deg beam	<b>EX12LED-3BD-8M</b>
<b>EX12LED-3BD-8W Infrared Illuminator</b> EX12LED, IR Illuminator, 850 nm, 60 deg beam	<b>EX12LED-3BD-8W</b>
<b>EX12LED-3BD-9M Infrared Illuminator</b> EX12LED IR Illuminator, 940 nm, 30 deg beam	<b>EX12LED-3BD-9M</b>
<b>EX12LED-3BD-9W Infrared Illuminator</b> EX12LED, IR Illuminator, 940 nm, 60 deg beam	<b>EX12LED-3BD-9W</b>
<b>LTC 3764/20 Varifocal Lens IR corrected</b> 1/2-inch, 4 – 12 mm, DC-iris, C-mount F1.2-360, 4-pin	<b>LTC 3764/20</b>
<b>LTC 3774/30 Varifocal Lens IR corrected</b> 1/2-inch, 10 – 40 mm, DC-iris, C-mount F1.4-360, 4-pin	<b>LTC 3774/30</b>
<b>TC8235GIT Ground Loop Isolation Transformer</b>	<b>TC8235GIT</b>
<b>UPA-2410-60 Power Supply</b> 120VAC, 60Hz, 24VAC, 10VA Out	<b>UPA-2410-60</b>
<b>UPA-2430-60 Power Supply</b> 120VAC, 60Hz, 24VAC, 30VA Out	<b>UPA-2430-60</b>
<b>UPA-2450-60 Power Supply</b> 120VAC, 60Hz, 24VAC, 50VA Out	<b>UPA-2450-60</b>
<b>UPA-2420-50 Power Supply</b> 220VAC, 50Hz, 24VAC, 20VA Out	<b>UPA-2420-50</b>
<b>UPA-2450-50 Power Supply</b> 220VAC, 50Hz, 24VAC, 50VA Out	<b>UPA-2450-50</b>
<b>S1374 Adapter</b> converts C mount lens to CS mount camera	<b>S1374</b>
<b>Software Options</b>	
<b>VP-CFGSFT Configuration Software</b> for cameras using Bilinx, includes VP-USB Adaptor	<b>VP-CFGSFT</b>

**Americas:**  
Bosch Security Systems, Inc.  
130 Perinton Parkway  
Fairport, New York, 14450, USA  
Phone: +1 800 289 0096  
Fax: +1 585 223 9180  
security.sales@us.bosch.com  
www.boschsecurity.us

**Europe, Middle East, Africa:**  
Bosch Security Systems B.V.  
P.O. Box 80002  
5600 JB Eindhoven, The Netherlands  
Phone: +31 40 2577 284  
Fax: +31 40 2577 330  
emea.securitysystems@bosch.com  
www.boschsecurity.com

**Asia-Pacific:**  
Robert Bosch (SEA) Pte Ltd, Security Systems  
11 Bishan Street 21  
Singapore 573943  
Phone: +65 6571 2600  
Fax: +65 6571 2698  
apr.securitysystems@bosch.com  
www.boschsecurity.com

**Represented by**