

MAP 5000 kit small

www.boschsecurity.com



BOSCH
Invented for life



- ▶ Supports up to two multi-language touch screen control centers
- ▶ Supports one LSN gateway module with up to 127 LSN devices
- ▶ Eight supervised inputs and one unsupervised tamper input
- ▶ Supports additional power supplies
- ▶ Event reporting via Ethernet (optional)

This MAP kit includes one MAP panel 5000 small, one MAP Control Center (touch screen keypad), one MAP LSN Gateway Module, one MAP Power Supply 150W and one MAP Panel Enclosure Kit. Using a Bosch Data Bus (BDB) based on Controller Area Network (CAN) technology as the internal and external bus, the panel supports a range of applications as part of the scalable Modular Alarm Platform 5000 system. The panel mounts on the MAP Hinged Mounting Plate in the MAP Panel Enclosure Kit. This provides easy access to all wiring terminals and communication port connectors.

System overview

MAP panel

Terminals and connectors - front view

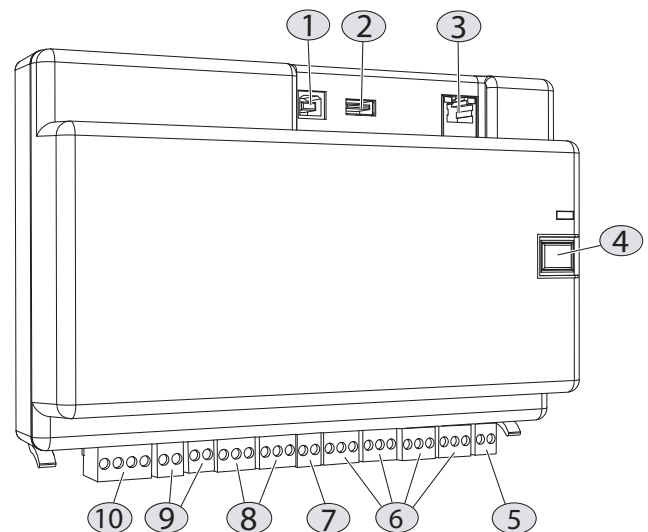

| Element | Description |
|---------|--|
| 1 | USB host port – currently not enabled |
| 2 | USB port – currently not enabled |
| 3 | Ethernet port |
| 4 | Installer switch |
| 5 | Tamper switch input |
| 6 | Eight supervised inputs |
| 7 | Auxiliary power output |
| 8 | Two form C dry-contact relay outputs |
| 9 | Two auxiliary switched voltage outputs |
| 10 | External Bosch Data Bus (BDB) port |

Terminals and connectors - back view

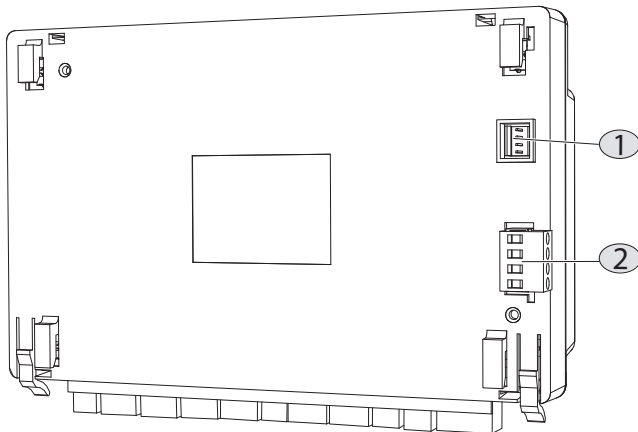

| Element | Description |
|---------|------------------------------------|
| 1 | Power supply input connector |
| 2 | Internal Bosch Data Bus (BDB) port |

MAP Control Center (touch screen keypad)

Main menu - screen 1



| Element | Component | Description |
|---------|---------------------|--|
| 1 | Screen name | This information identifies the active screen. |
| 2 | Menu buttons | These buttons are used to perform tasks. |
| 3 | Installer mode icon | This icon indicates that the control panel is in installer mode. |
| 4 | RPS connected icon | This icon indicates that remote programming software is connected to the control panel. |
| 5 | Information button | This button is used to view additional system information and to clear events, alarms or troubles. Flashing red: not yet cleared system events and alarms Flashing yellow: not yet cleared system troubles Green: no additional system information available |
| 6 | Navigation bar | These buttons are used to navigate through the system, to find tasks or to view system information. Grayed out buttons are not activated. |

Additional power

To provide additional power for remote control centers, use the ICP-MAP0120 MAP Expansion Enclosure Kit (power supply application).

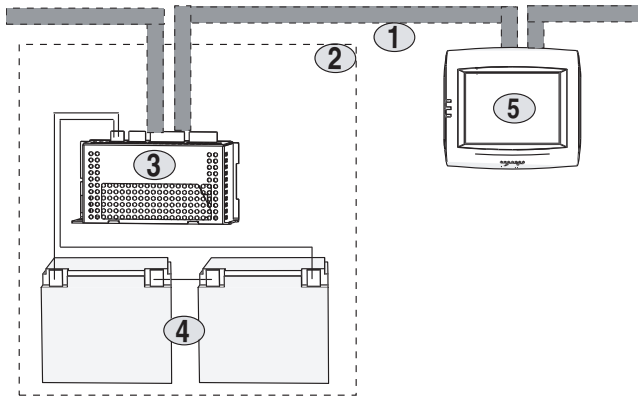

| Element | Description |
|---------|--|
| 1 | Bosch data bus |
| 2 | ICP-MAP0120 MAP Expansion Enclosure Kit |
| 3 | ICP-MAP0005-2 MAP Power Supply 150W |
| 4 | Batteries: up to two 12 V, 18 Ah batteries connected in series |
| 5 | IUI-MAP0001-2 MAP Control Center (touch screen keypad) |

Functions

MAP panel 5000 small

Together with a MAP LSN Gateway Module, the panel supports up to 600 addresses, 500 areas, and 996 users. As part of a Modular Alarm Platform 5000 solution, the panel connects to building management systems through internet protocol (IP).

Bosch Data Bus (BDB) based on CAN technology

The panel provides two data buses:

- **Internal BDB** – Limited to 3 m in total length, the internal BDB connects the panel to other MAP devices.
- **External BDB** – Up to 1000 m in total length, the external BDB allows command centers, LSN Gateways, CAN Splitter Modules and power supplies to be placed at the point of use, promoting greater efficiency.

Inputs and outputs

The panel supports one unsupervised tamper input and eight supervised inputs. It also supports one auxiliary output, two Form C dry-contact relay outputs, and two programmable outputs for local notification devices.

The auxiliary output and both power outputs are over-current protected. The outputs are designed to provide individual protection. As a result, if a short circuit occurs on one output, the fault does not adversely affect the operation of another output.

Firmware upgrades

The firmware of all devices in the MAP system can be upgraded or updated with the Bosch Remote Programming Software (RPS). This allows for on-site or off-site (IP through Ethernet) upgrades or updates.

Communication with Bosch Software Packages

The MAP system allows separate communication with the following:

- **Management systems**
- **Bosch Remote Programming Software (RPS)**
Programming and diagnostic software for control panels that provides remote programming, record storage, remote control, and diagnostics options.

MAP Control Center (touch screen keypad)

Touch Screen

The control center has a resistive touch screen, which allows the user to use it directly as an input device without the static nature of physical keys. This provides a more dynamic and intuitive interaction with graphics and icons. Thin-film transistor liquid crystal display (TFT-LCD) technology provides excellent image quality.

The encapsulated electronic assembly protects against physical damage during handling and installation.

Audible Tones

The control center has a speaker and generates the following tones:

- **Accepted Button Press Tone:** Acknowledges when a user makes a selection by pressing an image on the touch screen.
- **Invalid Tone:** Indicates if the user touches an inactive button image or an area without a button image.
- **Entry Delay Tone:** Notifies the user to disarm the system within a specified programmable time period.
- **Exit Delay Tone:** Notifies the user that the system is preparing to arm within a specified programmable time period.
- **Intrusion Alarm Tone:** Indicates an alarm condition.
- **Intrusion Supervisory Tone:** Indicates a supervisory point trouble condition.
- **Intrusion Trouble Tone:** Indicates a point trouble condition.
- **Chime Tone:** Indicates a point activation.
- **System Trouble Tone:** Indicates a system trouble condition such as a main power failure.

Audio and visual controls

The control center has an integrated volume and brightness control. Because each control center is individually adjustable, changing the volume or brightness on one control center does not affect another control center on the same system. The volume adjustment only affects the volume of the control center, not the volume of alarms or trouble sounds.

Languages

For each user, a preferred language is selected when the user is created. When the user logs in, the preferred language is used at the command center.

Tamper Input

The control center enclosure has a built-in tamper switch to detect wall or cover removal.

MAP LSN Gateway Module

Fault Tolerance

The design for the loop circuit configuration tolerates a single short or a single open condition and still maintains full operation for all devices on the LSN loop.

Automatic Addressing

On one stub, both LSN classic mode and LSNi mode are supported simultaneously.

Bosch Remote Programming Software

Installers can use Bosch Security Systems, Inc. Remote Programming Software (RPS) to check and modify the configuration of devices on the gateway.

LSN Auxiliary Power Outputs

The gateway supports two individually over-current protected and supervised outputs.

MAP Power Supply 150W

Ground fault detection

The power supply detects ground faults of 25 kΩ or less in the system wiring, and reports the faults to the panel over the Bosch Data Bus.

Supervision Monitoring

The software monitors and communicates status information over the Bosch Data Bus for the following:

- AC input power
- Battery power
- Battery charger
- 28 VDC outputs (Output A, Output B)
- 24 VDC nominal switched auxiliary output

Indicators

Yellow and green light-emitting diodes (LEDs) and signal outputs indicate AC, battery, and BDB communication status.

Battery Charging Circuit

The battery charger provides 4.85 A nominal (5 A maximum) for all the outputs. The current available for recharging the batteries is this 4.85 A nominal current minus the current being supplied to all the other outputs (A and B outputs, Switched Auxiliary Output, and Panel Output).

If the AC power fails, the batteries must supply sufficient power to maintain operation for a specified period of time. The time for the delayed indication of AC power failure must be considered. With respect to 24VDC battery voltage the battery current is factor 1.3 higher than the load current. When AC power is restored, the batteries must be recharged within a specified period of time to 80% respective 100% of nominal capacity. The following table indicates the maximum available current for panel + consumers in consideration of the used battery configuration and recharge time:

| Recharge time in 100% | 24 hrs to 80% | 24 hrs to 100% | 48 hrs to 100% |
|-----------------------|---------------|----------------|----------------|
| 24V / 18 Ah | 3 A | 3 A | 3 A |
| 24V / 36 Ah | 3 A | 2.7 A | 3 A |
| 24V / 40 Ah | 2.9 | 2.5 A | 3 A |
| 24V / 72 Ah | 1.5 A | 1.2 A | 2.4 A |
| 24V / 80 Ah | 1.2 A | 0.8 A | 1.5 A |

Load-shed, Overvoltage Protection and Recovery

All connected batteries are permanently monitored for under voltage (<25VDC). Following an extended AC power failure, the power supply hardware and software disconnects a battery from all outputs if the battery voltage falls below 20 VDC. The load-shed eliminates the possibility of permanent degradation in the batteries. After AC power is restored to an appropriate operating voltage, the battery charger recharges the batteries.

The overvoltage protection prevents the output voltage from rising above the value of >30 VDC. Connected consumers are thereby protected against damage by overvoltage.

Temperature Compensation

The power supply adjusts the battery charge voltage to compensate for the air temperature around the batteries.

Certifications and approvals

| Region | Certification | |
|---------|---------------|---------------------------------------|
| Germany | VdS-S | S 112016 [MAP 5000] |
| | VdS | G111040 [ICP-MAP-5000] |
| Europe | CE | [MAP 5000 Modules] |
| | EN5013 1 | EN-ST-000121 [MAP 5000] |
| Poland | TE-CHOM | 03-16-o [ICP-MAP5000] |
| France | AFNOR | N1133400003A0 ICP-MAP5000-2 [MAP5000] |

Parts included

| Quantity | Component |
|----------|---|
| 1 | MAP panel 5000 small including: <ul style="list-style-type: none"> • Eight 12.1 kΩ EOL resistors • Two 120 Ω CAN terminal EOL resistors • One panel power cable • One 2-pin terminal plug (white) • One 2-pin terminal plug (dark blue) • Two 3-pin terminal plugs (orange) • Four 3-pin terminal plugs (dark blue) • One 4-pin terminal plug (green) |
| 1 | MAP Control Center (touch screen keypad) including: <ul style="list-style-type: none"> • Two screws M3 x 20 mm Torx |
| 1 | MAP LSN Gateway Module including: <ul style="list-style-type: none"> • CAN cable, short • Four terminal plugs (two brown, two white) |
| 1 | MAP Power Supply 150W including: <ul style="list-style-type: none"> • Two Bosch Data Bus (BDB) cables, long (with 4-pin terminal plug) • One thermistor cable (with 2-pin terminal plug) • One battery cable (with ring terminal) • One battery jumper cable (with ring terminal) • Two 2-pin terminal plugs (dark blue) • One 2-pin terminal plug (white) • One 3-pin terminal plug (orange) • One 4-pin terminal plug (green) • One 5-pin terminal plug (black) |
| 1 | MAP Panel Enclosure Kit including: <ul style="list-style-type: none"> • One MAP Panel Enclosure Tamper Switch • One MAP AC Terminal Block • One MAP Enclosure Lockset • Seven TORX screws (M4 x 8 mm, type A) • Two TORX screws (M3 x 5 mm) • Spiral wrap (large) • Drill template • Installation Manual |

Technical specifications

MAP panel 5000 small

Electrical

| | |
|-----------------------------------|-----|
| Minimum operating voltage in VDC | 19 |
| Maximum operating voltage in VDC | 29 |
| Rated voltage in VDC | 28 |
| Minimum current consumption in mA | 250 |
| Maximum current consumption in mA | 500 |
| Outputs | |

| | |
|--|--|
| Maximum current consumption in mA per output | 1000 |
| Relay outpouts | |
| Maximum operating voltage in VDC | 30 |
| Maximum operating voltage in VAC | 30 |
| Back-up time | Determined by battery capacity and system load. Consider time or capacity limits for recharging the batteries regarding local regulations or EN standards if needed. |

Mechanical

| | |
|--|--------------------------------|
| Dimension in cm (H x W x D) | 14.6 x 21.6 x 5.5 |
| Weight in g | 450 |
| Indicators | Green LED for operating status |
| Number of output modules | |
| Auxiliary output | 1 |
| Power output | 2 |
| Form C dry-contact relay output | 2 |
| Number of devices | |
| LSN Gateway Modules | 1 |
| Control Centers (touch screen keypads) | 2 |

MAP Control Center (touch screen keypad)

Electrical

| | |
|----------------------------------|-----|
| Minimum operating voltage in VDC | 16 |
| Maximum operating voltage in VDC | 29 |
| Rated voltage in VDC | 28 |
| Rated current in mA at 28 VDC | |
| Start-up | 250 |
| Alarm | 175 |
| Idle screen | 100 |
| Dark idle screen | 60 |

Mechanical

| | |
|-----------------------------|-------------------|
| Dimension in cm (H x W x D) | 15.6 x 17.1 x 3.9 |
| Weight in g | 363 |

| | |
|--|--|
| Housing material | ABS plastic |
| Color | white textured |
| Touch screen | |
| Type | TFT-LCD |
| Diagonal in cm | 14 |
| Aspect ratio | 4 : 3 |
| Resolution in pixels | 320 x 240 |
| Color depth | 16-bit color |
| Backlight | white LED with adjustable brightness (active and idle) |
| Indicators | 3 LEDs <ul style="list-style-type: none"> • green: power • yellow: fault • red: alarm |
| Connection type | 4-wire Bosch data bus, 2 sets of terminals for daisy chain in/out wiring |
| Maximum number of control centers (touch screen keypads) | 2 |

MAP LSN Gateway Module**Electrical**

| | |
|--------------------------------------|------------------------------|
| Minimum operating voltage in VDC | 16 |
| Maximum operating voltage in VDC | 29 |
| Rated voltage in VDC | 28 |
| Rated current in mA | 1600 |
| Standby current consumption | Dependent on LSN device load |
| Maximum LSN AUX output current in mA | 2 x 500 |

Mechanical

| | |
|-----------------------------|--|
| Dimension in cm (H x W x D) | 15.88 x 8.26 x 6.35 |
| Weight in g | 365 |
| Housing material | ABS plastic |
| Color | off-white |
| Indicator | Green power LED |
| Cable requirements | 0.6 mm – 1.0 mm (18 AWG - 22 AWG) solid or stranded; up to 1000 m line length; twisted type shielded |

MAP Power Supply 150W**Electrical**

| | |
|-----------------------------------|--------------------------------|
| Maximum operating voltage in VAC | 230 (-15 %, + 10%) |
| Minimum AC line frequency in Hz | 47 |
| Maximum AC line frequency in Hz | 63 |
| Minimum output voltage in VDC | 16 |
| Maximum output voltage in VDC | 30 |
| Minimum current consumption in mA | 1070 at rated load and 230 VAC |
| Maximum current consumption in mA | 100 at no-load and 24 VDC |

Battery

| | |
|-------------------------------------|----------------------------------|
| Battery configuration in VDC | 12 |
| Battery type | Lead battery, maintenance - free |
| Min. ampere hour rating in Ah | 18 |
| Max. ampere hour rating in Ah | 80 |
| Battery charge voltage in VDC | 27.6 (with thermal compensation) |
| Nominal battery charger output in A | 4.85 |
| Maximum battery charger output in A | 5 |

Outputs

| | |
|--|-------|
| Maximum sum of output (field-accessible or user-accessible) power in W | ≤ 109 |
| Maximum ripple of all voltage outputs in mV | ≤ 250 |

A and B output

| | |
|--------------------------------------|---|
| Type | Supervised, independently short-circuit protected |
| Minimum output voltage in VDC | 26 |
| Maximum output voltage in VDC | 30 |
| Rated voltage in VDC | 28 ± 1 |
| Rated current in mA (A or B) | 2000 |
| Rated current in mA (sum of A and B) | 3000 |

Switched auxiliary output

| | |
|-------------------------------|------------|
| Type | Supervised |
| Minimum output voltage in VDC | 24 |

| | |
|-------------------------------|-----|
| Maximum output voltage in VDC | 30 |
| Rated voltage in VDC | 24 |
| Rated current in mA | 500 |

Panel output

| | |
|-------------------------------|--------------|
| Type | Unsupervised |
| Maximum output voltage in VDC | 27.6 |
| Rated voltage in VDC | 24 |
| Rated current in mA | 500 |

Trouble output dry contacts

| | |
|----------------------------------|------|
| Maximum operating voltage in VDC | 30 |
| Rated current in mA | 1000 |

Mechanical

| | |
|-------------------------------|--|
| Dimension in cm (H x W x D) | 11.43 x 22.23 x 6.67 |
| Dimension in inch (H x W x D) | 4.5 x 8.75 x 2.63 |
| Weight in g | 590 |
| Weight in oz | 20.8 |
| Indicators | <p>Green LEDs indicate:</p> <ul style="list-style-type: none"> • AC good • Operation monitor <p>2x yellow LEDs indicate:</p> <ul style="list-style-type: none"> • BAT1/2 (on = missing battery, blinking = low battery) |

Number of inputs

| | |
|-------------------------------|---|
| Tamper switch input | 1 |
| Thermal compensation circuit* | 1 |

* If supplied thermistor is not used, a leaded 10 kΩ, 1%, ¼ W resistor must be placed across the trim terminals (does not comply with VdS). Out of tolerance high condition of the battery voltage is an indication of a missing trim resistor.

MAP Panel Enclosure Kit**Mechanical**

| | |
|-------------------------------|-------------------------------------|
| Dimension in cm (H x W x D) | 65.8 x 44.3 x 19.35 |
| Dimension in inch (H x W x D) | 25.9 x 17.4 x 7.6 |
| Weight in g | 1566 |
| Material | 1.5 mm (0.06 in.) cold rolled steel |
| Color | White |

MAP 5000 kit small**Environmental**

| | |
|-------------------------------------|---|
| Minimum operating temperature in °C | -10 |
| Maximum operating temperature in °C | 55 |
| Minimum storage temperature in °C | -20 |
| Maximum storage temperature in °C | 60 |
| Minimum relative humidity in % | 5 |
| Maximum relative humidity in % | 95 |
| Protection class | IP30 IP31 (built into the MAP Panel Enclosure with an edge protection profile) |
| Security level | IK04 IK06 (built into the MAP Panel Enclosure with an edge protection profile) |
| Environmental class | II: EN50130-5, VdS 2110 |
| Usage | Indoor |

Ordering information**MAP 5000 kit small**

Kit including one MAP panel 5000 small, one MAP Control Center (touch screen keypad), one MAP LSN Gateway Module, one MAP Power Supply 150W and one MAP Panel Enclosure Kit.

MAP panel 5000 with wiring terminals for tamper and power supply inputs, eight supervised inputs form C relay and auxiliary power outputs, switched voltage outputs, two Bosch Data Bus ports and an Ethernet port.

Suitable for 1 LSN Gateway and 2 Control Centers (touch screen keypad).

Order number **ICP-MAP5000-SKE**

Represented by:

Europe, Middle East, Africa:
Bosch Security Systems B.V.
P.O. Box 80002
5600 JB Eindhoven, The Netherlands
Phone: + 31 40 2577 284
emea.securitysystems@bosch.com
emea.boschsecurity.com

Germany:
Bosch Sicherheitssysteme GmbH
Robert-Bosch-Ring 5
85630 Grasbrunn
Germany
www.boschsecurity.com

North America:
Bosch Security Systems, Inc.
130 Perinton Parkway
Fairport, New York, 14450, USA
Phone: +1 800 289 0096
Fax: +1 585 223 9180
onlinehelp@us.bosch.com
www.boschsecurity.us

Asia-Pacific:
Robert Bosch (SEA) Pte Ltd, Security Systems
11 Bishan Street 21
Singapore 573943
Phone: +65 6571 2808
Fax: +65 6571 2699
apr.securitysystems@bosch.com
www.boschsecurity.asia