

eBridge100RMT

Ethernet over Coax/Cat5e Adapters for Extended Distances

Description

Altronix eBridge100RMT Ethernet over Coax/CAT5e Adapter Kit transmits full duplex data at 100Mbps and pass PoE compliant power over coax 304m, or CAT5e cable up to 500m without repeaters. The adapter kit consists of an eBridge100RM receiver and an eBridge100TM transceiver. These adapters, along with the connected IP camera or edge device, are powered by virtually any midspan or endspan. Remote management functions such as edge device reset, monitoring real-time current draw and port status are possible when coupled with an Altronix NetWay8M/16M Midspan. eBridge100RMT is compatible with Megapixel, HD720, HD1080, and VGA cameras.



Key Features

- IEEE 802.3af (15W) and IEEE 802.3at (30W).
- Eliminates the costs and labor associated with installing new network cabling.
- Retrofit digital IP cameras in an analog CCTV installation.
- Auto detection and protection of legacy non-PoE cameras/devices.
- Works with Megapixel, HD720, and HD1080 cameras.
- Extends Network link distance in an industrial environment.
- Upgrades deployed CCTV Coax to a digital network for Retail, Casinos, Airports, Schools, Hospitals, etc.
- UL Listed in the U.S. and Canada.
- CE Approved.
- C-Tick compliant.
- Lifetime Warranty / Made in the U.S.A.

Typical Application

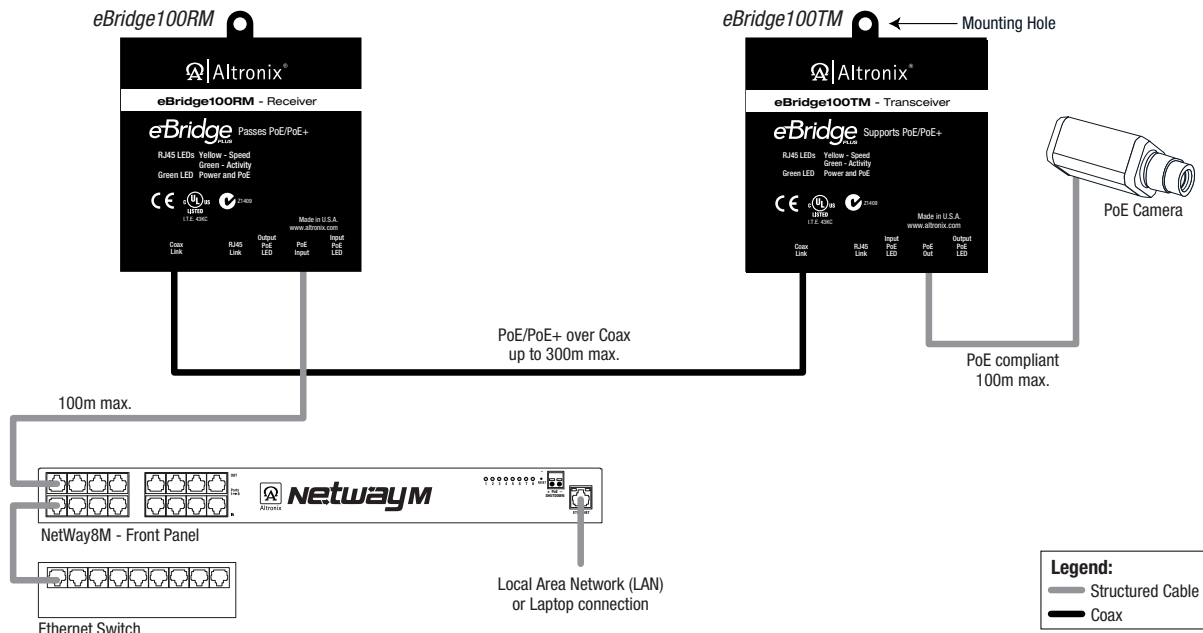

eBridge100RMT Ethernet over Coax/Cat5e Adapters for Extended Distances

Specifications

Input

eBridge100RM:	Powered by midspan or endspan.
eBridge100TM:	Powered by eBridge100RM.

Ethernet

Connectivity: RJ45, auto-crossover.
Wire type: 4-pair Cat-5 or better structured cable.
Distance: up to 100m.

Coax

Throughput is rated to pass 100Mbps of data at distances up to 300m.
With proper headend equipment multiple Megapixel cameras can be used.
Speed: 10/100BaseT, half/full duplex, auto negotiation.
Connectivity: BNC, RG-59/U or similar.

Indicators (LED)

Green LED:	PoE ON.
Yellow and Green LED (by RJ45 jack):	IP Link status, 10/100Base-T/active.

Agency Listings

UL/cUL	UL 60950-1 (Information Technology Equipment).
CE	European Conformity.
C-Tick compliant.	

Physical and Environmental

Dimensions (W x L x H)
3.5" x 4.375" x 1" (88.9mm x 111.1mm x 25.4mm).

Weight (approx.)

Product Weight	0.45 lbs. (0.2 kg).
Shipping Weight	0.8 lbs. (0.36 kg).

Temperature

Operating:	
eBridge100RM:	-20°C to 49°C (-4°F to 120.2°F).
eBridge100TM:	
For 15W:	-40°C to 75°C (-40°F to 167°F).
For 25W:	-40°C to 70°C (-40°F to 158°F).
For 30W:	-40°C to 49°C (-40°F to 120.2°F).

Storage: -20°C to 70°C (-4° to 158°F).

Relative Humidity 85% +/-5%.

Operating Altitude: -304.8 to 2,000m.